



ROOF PRODUCT RATING PROGRAM MANUAL

CRRC-1

© 2025 Cool Roof Rating Council, Inc. All Rights Reserved.

2435 N. Lombard Street
Portland, OR 97217
www.coolroofs.org

Phone (866) 465-2523

PREFACE

The CRRC Roof Product Rating Program has been developed under the direction of the Cool Roof Rating Council. The Cool Roof Rating Council was created to develop methods for evaluating and labeling the Radiative Properties of Roofing Products in an accurate manner and to disseminate the information to all interested parties. The Cool Roof Rating Council is a non-profit organization whose mission is:

To bring objective, scientific information related to cool surfaces to critical discussions and informed decisions about the impacts of heat islands, extreme heat, and energy use in the built environment.

By pursuing this mission, the CRRC will become the recognized informational resource for reducing the urban heat island effect, increasing building energy efficiency, improving occupant comfort, and mitigating the global climate effects of greenhouse gas emissions.

TABLE OF CONTENTS

CHAPTER 1.0 FOREWORD	5
1.1 Scope	5
1.2 Liability	5
1.2.1 Disclaimer	5
1.2.2 Indemnification	5
1.3 Membership and License Applications	5
1.3.3 Limitations	5
1.4 Glossary of Terms	5
1.4.1 Scope	5
1.4.2 Definitions	5
1.5 References	8
CHAPTER 2.0 ACCREDITED LABORATORIES, APPROVED TEST FARMS AND TESTING	9
2.1 General	9
2.2 Requirements for All Accredited Testing Laboratories	9
2.2.1 Laboratory Personnel	10
2.2.2 Interlaboratory Comparison Study	10
2.2.3 Test Specimen Measurements	10
2.2.4 Solar Reflectance Tests	10
2.2.5 Thermal Emittance Tests	11
2.2.6 Instrumentally-Measured Color Tests	11
2.2.7 Coating Thickness Tests	11
2.2.8 Single-Ply Thickness Tests	11
2.2.9 Reporting	11
2.2.10 Photographic Documentation	12
2.2.11 Weathering Tests	12
2.3 Special Requirements for Approved Manufacturer Testing Laboratories	12
2.4 Special Requirements for Accredited Independent Testing Laboratories.....	13
2.5 Requirements for Test Farms	13
2.5.1 Test Farm Application Requirements	13
2.5.2 Product Weathering Exposure and Removal Requirements	13
CHAPTER 3.0 CRITERIA FOR PRODUCT RATING AND ROOFING LICENSEES	14
3.1 General	14
3.2 Compliance with Criteria and Conditions	14
3.3 Licensee’s Representative	14
3.4 Quality Control.....	14
3.5 Initial and Aged Testing Requirements.....	14
3.5.1 Standard Production Line Roofing Products	14
3.5.2 Color Family Groups and Representative Elements	17
3.5.3 Color Family Additional Elements	17
3.5.4 Dual Ratings for Liquid-Applied Roof Coating Products	18
3.5.5 Variegated Products That Are Tested Under CRRC-1 Test Method #1	18
3.5.6 Requirements for CRRC Rapid Ratings	19
3.5.7 Products Tested Under ASTM E1918	19
3.5.8 Special Processes	20
3.5.9 Photographic Documentation	20
3.6 Validation Testing of Rated Products	20
3.7 Product Rating Authorization Procedures.....	21
3.8 Product Rating Applications	21
3.9 Formula Change	22
3.10 Product Retesting Due to Test Method Changes	22
3.11 Converting Standard Product to Color Family Product	22
3.12 CRRC Label Requirements	22
3.13 Confidentiality.....	22

3.14 Inactive Product Ratings	22
CHAPTER 4.0 CRRC LABEL USE	23
4.1 General	23
4.2 Licensed Use of the CRRC Label	23
4.3 Reproduction of Label.....	23
CHAPTER 5.0 REVOCATION OR CLOSING FILES.....	23
5.1 Scope	23
5.2 Reinstatement	24
5.3 Consultation	24
CHAPTER 6.0 COMPLAINTS	24
6.1 Purpose	24
6.2 Pre-Action Procedures.....	24
6.3 Submission	24
6.3.1 Notification.....	24
6.3.2 Review	24
6.3.3 Responsibility of Licensed Parties and Complainants.....	25
CHAPTER 7.0 APPEALS	25
7.1 General	25
7.2 Submission	25
7.3 Notification.....	25
7.4 Appeal Review	25
CHAPTER 8.0 ARBITRATION.....	26
8.1 General	26
8.2 Arbitration Method.....	26
8.3 Cost.....	26
8.4 Hearing.....	26
APPENDIX 1: DEVICES AND SERVICES TECHNICAL NOTE TN11-2*	27
APPENDIX 2: MONO-COLOR CALCULATION METHOD FOR VARIEGATED SHINGLES, STONE-COATED METAL, AND GRANULE-SURFACED ROLL PRODUCTS	35
APPENDIX 3: VALIDATION TESTING PROCEDURES.....	37
APPENDIX 4: PRODUCT RATING PROCEDURE DETAILS: INITIAL AND AGED TESTING	42
APPENDIX 5: COLOR FAMILY PROGRAM PROCEDURES	49
APPENDIX 6: PROCEDURES FOR REFORMULATED, RETESTED, OR INACTIVE PRODUCTS	53
APPENDIX 7: INSTRUCTIONS FOR MEASURING SOLAR REFLECTANCE AND THERMAL EMITTANCE OF ROOFING AGGREGATE LESS THAN OR EQUAL TO 5/8" NOMINAL SIZE.....	55
APPENDIX 8: STANDARD TEST METHOD FOR DETERMINING THE DIRECTIONAL-HEMISPHERICAL SOLAR REFLECTANCE OF MATERIALS USING A DIRECTIONAL-HEMISPHERICAL PORTABLE REFLECTOMETER	64
APPENDIX 9: PROCEDURES FOR PRODUCT RETESTING.....	72

ADVISORY NOTE: ALL REFERENCED DOCUMENTS SUCH AS CRRC AGREEMENTS, APPLICATIONS, FORMS, PROCEDURES OR OTHER ITEMS MAY BE FOUND AT

<https://coolroofs.org/programs/roof-rating-program/all-forms>

CHAPTER 1.0 FOREWORD

1.1 Scope

The Cool Roof Rating Council, Inc. (CRRC) operates a uniform rating system for the Radiative Properties of Roofing Products.

The system is supported by a rating program under which Manufacturers and sellers have the opportunity to label Roofing Products with measured initial and Aged Radiative Properties. These properties are determined and verified through testing by CRRC Accredited Independent Testing Laboratories (AITL) and a process of validation testing. The CRRC Roof Product Rating Program references ANSI/CRRC S100 - *Standard Test Methods for Determining Radiative Properties of Materials*.

Advisory Note: The CRRC does not specify minimum threshold values for Radiative Properties. The CRRC Roof Product Rating Program is not intended to be used as a primary law or regulation, but rather as an authoritative resource that complements adopted laws or regulations. If the CRRC Roof Product Rating Program is referenced by a law or regulation, the provisions of that law or regulation may dictate specific requirements that are in addition to or conflict with the CRRC Roof Product Rating Program. It is therefore the responsibility of the user to comply with applicable laws and regulations.

1.2 Liability

1.2.1 Disclaimer

The CRRC is the copyright owner of the CRRC rated products label, which bears one or more Radiative Property values reported by AITLs. The AITLs act independently from the CRRC.

A product Rating Authorization does not constitute a warranty by the CRRC regarding the Radiative Properties of a Roofing Product. A rating is not an endorsement of, or recommendation for, any Roofing Product. The CRRC is not a merchant in the business of selling Roofing Products, and therefore, cannot warrant products as to their merchantability or fitness for a particular use.

The CRRC therefore disclaims any and all liability, including but not limited to, damages for personal or other injury, lost profits, lost savings or other consequential or incidental damages that may arise from or in connection with:

1. services provided by, decisions made by or reports issued or granted by any AITL, any CRRC Licensee;
2. reliance on any CRRC product description, specification, rating or test, whether appearing in

a report, product Rating Authorization, printed or electronic directory or on a product label; or

3. the sale or use of any CRRC Rated Roofing Product.

1.2.2 Indemnification

Licensees are required to enter into Licensee Agreement with the CRRC, which contains, among other provisions, an indemnification of the CRRC, its Board of Directors (Board), officers, and agents from and against liability.

1.3 Membership and License Applications

The use of official CRRC forms is required when applying for CRRC membership, CRRC licenses, and to become an approved CRRC testing laboratory or test farm. Official CRRC forms can be found online at www.coolroofs.org. Product rating applications and test results shall be submitted via the CRRC Online Rating Portal.

1.3.3 Limitations

The application shall be limited to the holder of the rights of materials and products for which the Rating Authorization is sought. For applications that reference another rated product, the application shall include documentation that the applicant has authorization from the Manufacturer to use the test report data.

1.4 Glossary of Terms

1.4.1 Scope

Unless otherwise expressly stated, the following words and terms shall have the meanings as indicated in this document.

1.4.2 Definitions

Accredited Testing Laboratory - A laboratory that has received formal recognition by the CRRC as having demonstrated technical competency to perform specific types of tests, in accordance with Chapter 2.0.

Accredited Independent Testing Laboratory – An Accredited Testing Laboratory that is approved by the CRRC to test Roofing Products and is completely independent from any CRRC Licensee.

Approved Manufacturer Testing Laboratory – A testing laboratory affiliated with a CRRC Licensee that is approved by the CRRC to test the color properties of Roofing Products.

Agreement, Accredited Laboratory - A written agreement that is entered into between the CRRC and a CRRC-approved testing laboratory.

Agreement, Licensee - A written agreement which is entered into between the CRRC and a Licensee.

Agreement, Approved Test Farm - A written agreement that is entered into between the CRRC and a CRRC Approved Test Farm.

Approved Test Farm - A company that the CRRC has approved to conduct exposure activities for products that are undergoing the process to obtain aged ratings.

Batch - A single quantity of product processed at one time as a mixture or combination of raw materials.

Challenge Testing - Validation Testing that is triggered by concerns raised by a CRRC Licensee, the CRRC, or another entity about Product Ratings that are listed on the CRRC Rated Roof Products Directory.

Coating Thickness – The dry film Thickness of a coating when applied to a substrate.

Color Family - A CRRC pre-defined range of Hunter “L,” “a,” and “b” color coordinates that establishes the color space for a CRRC pre-defined set of seventeen colors.

Color Family Additional Element - A factory-applied metal roof coating that is part of a CRRC Licensee’s Color Family Group and not the Representative Element.

Color Family Element - Any Representative or Additional Element within a CRRC Licensee’s Color Family Group.

Color Family Group - One or more factory-applied metal roof coatings that are rated by one CRRC Licensee and have the same Binder/Resin Technology, and that have color properties and Radiative Properties that fall within the ranges established for the respective CRRC Color Family. The first eight digits of the CRRC product identification number are the same for each individual color in a Color Family Group.

Color Family Representative Element - A factory-applied metal roof coating that is used to initially establish a CRRC Licensee’s Color Family Group.

Color Family Binder/Resin Technology - General class of Factory-Applied Coatings used in metal Roofing Products which are defined by the family of related Binder/Resin chemicals used to formulate such coatings.

Compound Product Rating - A compound product application, and therefore listing, refers to an application in which a CRRC Licensee submits test results (or Reference Application) for two or more products that they assert are the same surface formulation and have the same Radiative Properties and that they propose to list together as one product entry on the CRRC Rated Roof Products Directory.

Directionally Reflective Material - A Roofing Product material with Solar Reflectance that varies with solar incidence angle.

Emittance, Thermal - The ratio of the radiant heat flux emitted by a Specimen to that emitted by a blackbody radiator at the same temperature.

Factory-Applied Roof Product Component - A material or component made by a CRRC Licensee which is applied to a substrate in a factory or coating facility.

Formula Change - Individual or accumulated changes in resin, pigment, pigment grind, materials ratios or anything which in aggregate changes Solar Reflectance or Thermal Emittance by 0.05 or more.

Hunter “L,” “a,” “b” Color Coordinate - A numeric measurement of a color’s lightness (L), redness/greenness (a) and yellowness/blueness (b) – in accordance with ASTM E805, Section 9. Color Measurement Equipment Specification: 0°/45° or 45°/0° (illuminant angle/viewing angle) geometry with 10° standard observer, D65 illuminant.

Inactive Product Rating - Any product rating that is removed from the CRRC Rated Roof Products Directory due to Licensee request or non-payment of fees and relocated to an Inactive Product Rating List.

Incorrectly Exposed - A Specimen that is unusable after weathering exposure due to improper exposure placement by the Test Farm. Incorrectly Exposed Specimens shall include, but not be limited to, Specimens that are placed face down (e.g., with the test surface facing the test fence), Specimens that are mounted at the incorrect tilt, or any other exposure practice that does not comply with the requirements of this program manual.

Label, CRRC - The distinctive informational mark that contains the CRRC Logo and other pertinent Radiative Property information specific to a Roofing Product.

Licensed Party - An entity that is a CRRC Licensee or approved testing Laboratory.

Licensee - A Roofing Product seller that has met and maintains compliance with the Program requirements and has signed the CRRC Licensee Agreement. Licensees may or may not manufacture their products, purchase them from another Manufacturer, or both.

Logo, CRRC - The distinctive registered service mark of the CRRC.

Low-Sloped Roof - A roof surface with a slope (rise to run) ratio of less than 2:12 (9.5 degrees from the horizontal).

Manufacturer, Roofing Product - A company that produces Roofing Products.

Practice for Laboratory Aging of Roofing Materials –

A laboratory standard practice that replicates the effects of three years of natural exposure, including soiling and weathering, on the Solar Reflectance and Thermal Emittance of roofing materials. This practice shall be conducted in accordance with ASTM D7897, using the soiling mixture for average U.S. conditions specified in section 6.1 of ASTM D7897.

Profiled Roofing Products - Roofing Products with geometries that vary in rise over a given width, as can be seen in a cross-sectional view; Roofing Products that are not planar or flat.

Radiative Properties - The Solar Reflectance and Thermal Emittance of a Roofing Product.

Radiative Properties, Rated - The Solar Reflectance and Thermal Emittance of a Roofing Product, which is reported on a CRRC product label and published on the CRRC Rated Roof Products Directory.

Radiative Properties, Aged - The Solar Reflectance and Thermal Emittance of a Roofing Product aged that is weathered and tested in accordance with sections 2.5.2 and 3.5, respectively.

Radiative Properties, Initial - The Solar Reflectance and Thermal Emittance of a Roofing Product that is tested in accordance with section 3.5.

Radiative Properties, Laboratory Aged - The Solar Reflectance and Thermal Emittance of a Roofing Product that is laboratory aged and tested in accordance with sections 3.5.

Radiative Properties, Tested - The reported Solar Reflectance and Thermal Emittance of a Roofing Product as determined by a CRRC Accredited Independent Testing Laboratory.

Rapid Ratings – An optional CRRC product rating process which develops interim laboratory-aged values in accordance with section 3.5.6 of this document.

Rating Authorization – An official notification from the CRRC to a CRRC Licensee, authorizing the Licensee to use the CRRC product label for one or more products.

Reactivated Product - A product which was previously inactive and is reactivated by Licensee request.

Reflectance, Solar - The ratio of the reflected flux to the incident flux.

Responsible Person - An individual employee of an Accredited Independent Testing Laboratory who has participated in a CRRC laboratory training workshop and who will supervise or perform all CRRC-related testing of Roofing Products at that laboratory.

Retested Product - A CRRC rated product that replaces an original product rating due to Validation Testing failure, test method changes, or discontinuation for any other reason.

Roofing Product - A material designed, manufactured and constructed as the uppermost part of the roof assembly that is in direct contact with solar radiation.

Roofing Product, CRRC Rated - A Roofing Product that has successfully completed the CRRC product rating process, is posted on the CRRC Rated Roof Products Directory, and has a CRRC rated product label.

Roofing Product, Liquid-Applied Roof Coating - A liquid-applied product that is installed to a roof covering.

Roofing Product, Liquid-Applied Roof Covering - A liquid-applied product that is installed to a substrate to serve as a roof covering.

Roofing Product, Polymer/Composite Molded Shake/Slate/Tile Shaped – polymer-based material formed into a shake, slate, or Tile facsimile.

Roofing Product, Multi-Shade Polymer/Composite – a Polymer/Composite Molded Shake/Slate/Tile Shaped product that is sold as a set containing a mix of multiple shades with the same surface formulation.

Roofing Product, Privately-Labeled - A Roofing Product manufactured by an entity other than the CRRC Licensee bringing it to market.

Roofing Product, Production Line - Production Line Roofing Products are standard color offerings by the Manufacturer and are promoted in general product information and in marketing materials.

Roofing Product, Single-Ply Membrane – a flexible synthetic polymer-based sheet applied to the roof in a single layer, whose primary function is the exclusion of water.

Roofing Products, Standard – CRRC-rated Production Line Roofing Products, excluding Color Family products.

Roofing Product, Stone-Coated Metal – Roofing materials composed of metal sheets that are formed into various shapes and surfaced with a coating and stone granules.

Roofing Product, Tile - A rigid cladding, typically clay or concrete, that is installed in overlapping pieces to cover a roof.

Roofing Product, Variegated - A material with a varied surface color or has discrete markings of different colors.

Sample – A set of test Specimens.

Sample Array - An assembly of Roofing Product Specimens for testing and exposure.

Single-Ply Thickness – The overall Thickness of a Single-Ply Membrane, excluding any fabric backing.

Solar Reflectance Index (SRI) - A calculated value that combines Solar Reflectance and Thermal Emittance into a single metric following *Approach I* from Section 6.1.1 of ASTM E1980-11 (2019) using only equations 1 and 3 and a convective coefficient of $12 \text{ W} \cdot \text{m}^{-2} \cdot \text{K}^{-1}$ (medium wind speed). Values typically range from 0 to 100, with especially dark or reflective products exceeding these bounds.

Specimen – A portion of a product for use in testing and weathering.

Steep-Sloped Roof – A roof surface with a slope (rise to run) ratio **greater than or equal to 2:12** (9.5 degrees from the horizontal).

Substrate, Rough – An application surface that is equally coarse or coarser than a new (i.e., unweathered) #11 granulated modified bitumen sheet.

Substrate, Smooth – An application surface that is less coarse than a new (i.e., unweathered) #11 granulated modified bitumen sheet.

Substrate, Standard – A 3003 H14 uncoated aluminum metal panel.

Terminated Product Rating – Any product rating that is permanently removed from the CRRC Rated Roof Products Directory due to Validation Testing failure or retesting requirements and relocated to the Inactive Product Rating List. Terminated products are not eligible for reactivation.

Test Farm Site - An authorized location where a product is placed for three-year weathering exposure before aged testing is conducted.

Uncharacteristically Damaged - A Specimen that is unusable for weathering exposure placement or unusable after weathering exposure through no fault of Specimen preparation by the CRRC Licensee. Unusable refers to the inability to accurately measure the Aged Radiative Properties of the product Specimen. Uncharacteristically Damaged shall include, but not be limited to, the following: damage during transit of the product by improper handling; animal excrement that stained the Specimen; irreparable damage or destruction due to a natural disaster, such as a hurricane, tornado, flooding, or other disaster; or any other unforeseen event that might harm the Specimen beyond normal weather exposure.

Wood Roofing Products - Roofing Products manufactured from various trees, including but not limited to western red cedar, cypress, pine, and redwood.

1.5 References

ANSI/ASHRAE Standard 169-2021 - Climatic Data for Building Design Standards, American Society of Heating, Refrigerating and Air-Conditioning Engineers (ASHRAE), Atlanta, GA, USA.

ANSI/CRRC S100 - *Standard Test Methods for Determining Radiative Properties of Materials* (2025), Cool Roof Rating Council, Portland, OR.

ASTM C1371-12 (2022) - *Standard Test Method for Determination of Emittance of Materials Near Room Temperature Using Portable Emisometers*, ASTM International, West Conshohocken, PA, USA. <https://doi.org/10.1520/C1371-15>.

ASTM C1549-16 (2012), *Standard Test Method for Determination of Solar Reflectance Near Ambient Temperature Using a Portable Solar Reflectometer*, ASTM International, West Conshohocken, PA, USA. <https://doi.org/10.1520/C1549-09>.

ASTM C1864-17 (2022), *Standard Test Method for Determination of Solar Reflectance of Directionally Reflective Material Using Portable Solar Reflectometer*, ASTM International, West Conshohocken, PA, USA. <https://doi.org/10.1520/C1864-17E01>.

ASTM D751-(2019), *Standard Test Methods for Coated Fabrics*, ASTM International, West Conshohocken, PA, USA. <https://doi.org/10.1520/D0751-19>.

ASTM D1005-95 (2020), *Standard Test Method for Measurement of Dry-Film Thickness of Organic Coatings Using Micrometers*, ASTM International, West Conshohocken, PA, USA. <https://doi.org/10.1520/D1005-95R20>.

ASTM D7091 (2022), *Standard Practice for Nondestructive Measurement of Dry Film Thickness of Nonmagnetic Coatings Applied to Ferrous Metals and Nonmagnetic, Nonconductive Coatings Applied to Non-Ferrous Metals*, ASTM International, West Conshohocken, PA, USA. <https://doi.org/10.1520/D7091-21>.

ASTM D7897 (2018), *Standard Practice for Laboratory Soiling and Weathering of Roofing Materials to Simulate Effects of Natural Exposure on Solar Reflectance and Thermal Emittance*, ASTM International, West Conshohocken, PA, USA. <https://doi.org/10.1520/D7897-18>.

ASTM E805-22, *Standard Practice for Identification of Instrumental Methods of Color or Color-Difference Measurement of Materials*, ASTM International, West Conshohocken, PA, USA. <https://doi.org/10.1520/E0805-12AR17>.

ASTM E1918-21, *Standard Test Method for Measuring Solar Reflectance of Horizontal and Low-Sloped Surfaces in the Field*, ASTM International, West Conshohocken, PA, USA. <https://doi.org/10.1520/E1918-21>

ASTM E1980-11 (2019), *Standard Practice for Calculating Solar Reflectance Index of Horizontal and Low-Sloped Opaque Surfaces*, ASTM International, West Conshohocken, PA, USA. <https://doi.org/10.1520/E1980-11R19>.

ASTM G147 (2017), *Standard Practice for Conditioning and Handling of Nonmetallic Materials for Natural and Artificial Weathering Tests*, ASTM International, West Conshohocken, PA, USA. <https://doi.org/10.1520/G0147-17>.

ISO/IEC 17025 (2017), *General Requirements for the Competence of Testing and Calibration Laboratories*, International Organization for Standardization, Geneva, Switzerland.

CHAPTER 2.0 ACCREDITED LABORATORIES, APPROVED TEST FARMS AND TESTING

2.1 General

This chapter contains the requirements for Accredited Independent Testing Laboratories (AITL), Approved Manufacturer Testing Laboratories (AMTL), and Approved Test Farms. All Production Line Roofing Products must be tested by an AITL. AITLs and Approved Test Farms are to remain separate and unaffiliated entities.

2.2 Requirements for All Accredited Testing Laboratories

Product testing for a CRRC product rating must be conducted by accredited CRRC-approved testing laboratories. The requirements for testing laboratory approval are:

- (A) The laboratory must submit a completed application and Test Lab Agreement to the CRRC for consideration as a recognized CRRC Accredited Testing Laboratory, and pay the required fee;
- (B) A list of test methods on their current ISO 17025 scopes of accreditation. The scope must list the CRRC-approved test methods the test lab performs for the CRRC Roof Rating Program;
- (C) At least one employee of the Accredited Testing Laboratory must participate in a CRRC laboratory training workshop (see section 2.2.1). This employee shall be designated as a Responsible Person for CRRC testing. All testing for CRRC product ratings shall be performed or supervised by the Responsible Person, who shall ensure that test results are reported in accordance with section 2.2.9 of this program manual;
- (D) After participating in a CRRC laboratory training workshop, the laboratory must demonstrate competency prior to approval by completing testing on a set of Specimens provided by the CRRC. The Specimens shall be the most recently completed Interlaboratory Comparison Study materials or an alternative set of Specimens with existing test data. The evaluation of the laboratory's test results shall be conducted following the same criteria that were used to evaluate the existing data;
- (E) The laboratory must demonstrate ongoing competency by participating in the CRRC's

Interlaboratory Comparison Study in accordance with section 2.2.2 of this program manual; and

- (F) The laboratory must not be a CRRC Approved Test Farm or an affiliate of a CRRC Approved Test Farm.
- (G) Standard Laboratory Conditions for Laboratory-Based Testing
 - a. AITLs shall measure Specimens in a controlled environment under Standard Laboratory Conditions (23°C ± 3°C (73°F ± 5°F) Room Air Temperature and 50% ± 10% Relative Humidity).
 - b. AITLs shall indicate on the test results page in the CRRC Online Rating Portal that test Specimens were measured under Standard Laboratory Conditions.

2.2.1 Laboratory Personnel

An Accredited Testing Laboratory shall demonstrate compliance with CRRC program requirements by:

- (A) providing the CRRC with the name and contact information of the test lab employee who participated in a CRRC laboratory training workshop (i.e. Responsible Person) during the CRRC accreditation application process; and
- (B) notifying the CRRC within 10 business days of any personnel changes as they pertain to the Responsible Person(s) who is testing products for the CRRC Roof Product Rating Program. To maintain approval, a laboratory must retain at least one Responsible Person to perform testing, ensure that test results are accurately reported to the CRRC.

2.2.2 Interlaboratory Comparison Study

As part of ongoing compliance with CRRC approval, laboratories and test farms are required to participate in the biennial Interlaboratory Comparison Study. Participants shall report the Solar Reflectance, Thermal Emittance, and Thickness (where applicable), for a Sample set of products provided by the CRRC in accordance with sections 2.2.4 through 2.2.9 of this program manual. Laboratories that test colorimetry must also report color measurements, where applicable (see section 2.3 of this program manual). Test farms also shall test colorimetry (see section 2.5 of this program manual).

The purpose of the Interlaboratory Comparison Study is to conduct a periodic evaluation to ensure consistency and competency of the testing laboratory by evaluating the

test results against the rest results of the other participating laboratories and test farms values.

The CRRC shall notify participants of the results at the completion of the Interlaboratory Comparison Study, and shall notify the participant of any corrective actions that may be necessary.

2.2.3 Test Specimen Measurements

- (A) AITLs shall conduct one measurement per Specimen width and Specimen length;
- (B) Specimen measurements shall be within 2.54 centimeters (one inch) of the minimum required Specimen dimension;
- (C) Specimens shall be measured to an accuracy of 0.64 centimeters (0.25 inches); and
- (D) AITLs shall indicate on the test results page in the CRRC Online Rating Portal if test Specimens meet the size requirements. If Specimens do not meet the size requirements, the AITL will notify the Licensee and obtain new test Specimens that meet the CRRC's minimum size requirements for that product type.

2.2.4 Solar Reflectance Tests

Solar Reflectance tests shall be conducted in accordance with R.S.2.2 of ANSI/CRRC S100 or CRRC-1 Appendix 8, *Standard Test Method for Determining the Directional-Hemispherical Solar Reflectance of Materials Using a Directional-Hemispherical Portable Reflectometer*, with the exception of the requirements below. When following CRRC-1 Appendix 8, use solar spectral irradiance E891BN.

- (A) Wood Products. The product rating method for Wood Products is developed for cedar Roofing Products made from Western Red Cedar or Alaskan Yellow Cedar. Wood Products shall be tested in accordance with R.S.2.2(G) of ANSI/CRRC S100.

Advisory Note: The CRRC provides an Excel tool that calculates the standard error and records the locations of the measurements. Please contact info@coolroofs.org to receive a copy of these resources.

- (B) Directionally Reflective Roofing Products. Directionally reflective Roofing Products shall be tested in accordance with R.S.2.2(E) of ANSI/CRRC S100. The product rating label for Solar Reflectance shall be based on the summer measurement at an angle of 20 degrees. This representative measurement is the reported Solar Reflectance value for the entire year ($R_{sum}=R_{20}$).
- (C) Aggregate Roofing Products. Aggregate Roofing Products larger than 1.59 centimeters (5/8 inch) shall be tested in accordance with *ASTM E1918 - Standard*

Test Method for Measuring Solar Reflectance of Horizontal and Low-Sloped Surfaces in the Field. Aggregate Roofing Products larger than a standard size #11 granule and less than or equal to 1.59 centimeters (5/8 inch) shall be tested using ASTM E1918 or Appendix 7 of this program manual.

- (D) Multi-Shade Polymer/Composite Products. Polymer/Composite products that are sold as a set containing multiple shades with the same surface formulation (e.g., an equal mix of light, medium, and dark panels) shall be tested in accordance with Section R.S.2.2(F) of ANSI/CRRC S100.
- (E) ASTM E903. If ASTM E903 is used to measure Solar Reflectance, the following requirements apply.
 - a. The integrating sphere shall be fitted with a wall mount. A center mount shall not be used.
 - b. ASTM E903 may only be used to measure the Solar Reflectance of specimens with surfaces that are flat and uniform in color. ASTM E903 shall not be used to measure surfaces that are profiled, textured, or variegated in color.
 - c. ASTM E903 shall not be used for aged testing or Rapid Ratings testing.

2.2.5 Thermal Emittance Tests

Thermal Emittance tests shall be conducted in accordance with R.S.2.3 of ANSI/CRRC S100. The following additional requirements shall be observed:

- (A) Aggregate Roofing Products. Aggregate Roofing Products up to 1.59 centimeters (5/8 inch) shall be tested in accordance with Appendix 7 of this program manual.
- (B) Uninsulated metal Roofing Products and Factory-Applied Coatings on an uninsulated metal substrate. Roofing Products that are uninsulated metal or a Factory-Applied Coating on an uninsulated metal substrate (excluding Stone-Coated Metal Products) may be tested in accordance with either ASTM C1371 or the Slide Method.
- (C) Curved Products. Bellows shall be used in accordance with Appendix 1 of this program manual for Thermal Emittance testing of curved products.

2.2.6 Instrumentally-Measured Color Tests

Products that are designated as Color Family Elements shall be tested in accordance with R.S.2.4 of ANSI/CRRC S100 and Appendix 5 of this program manual.

2.2.7 Coating Thickness Tests

Thickness tests shall be conducted for Liquid-Applied Roof Coatings, in accordance with R.S.2.5 of ANSI/CRRC S100.

2.2.8 Single-Ply Thickness Tests

- (A) The Licensee submitting the Single-Ply product for testing must declare the Manufacturer's specified Thickness of the product as part of their application in the CRRC Online Rating Portal.
- (B) The Thickness of Single-Ply products shall be verified upon initial testing by an AITL in accordance with ASTM D751, Section 9.
- (C) A Thickness measurement shall be taken at each of five evenly-spaced points on each of the nine product Specimens. The measured average Thickness of each Specimen shall be determined as the mean of its five-point measurements. If a Specimen's measured average Thickness does not meet the Thickness tolerance specified by the relevant ASTM standard for the Sample material, the Specimen shall not be used for CRRC ratings and the AITL shall notify the Licensee to supply a replacement Specimen. If no ASTM standard exists for the Sample material or the relevant ASTM standard does not specify a Thickness tolerance, the measured average Thickness must be no more than 15% greater or no more than 10% less than the Manufacturer's specified Thickness.

2.2.9 Reporting

Reporting of Tested Radiative Properties shall be in accordance with R.S.2.8 of ANSI/CRRC S100. Solar Reflectance measurements shall be reported to three decimal places and Thermal Emittance measurements shall be reported to two decimal places.

When Solar Reflectance Index is calculated, Approach I from Section 6.1.1 of ASTM E1980-11 (2019) shall be followed using only equations 1 and 3 and a convective coefficient of $12 \text{ W} \cdot \text{m}^{-2} \cdot \text{K}^{-1}$ (medium wind speed). Effective July 10, 2023, the Solar Reflectance input shall be rounded to three decimal places and the Thermal Emittance input shall be rounded to two decimal places.

If testing is conducted using CRRC-1 Test Method #1, the AITL must provide the CRRC with an Excel file documenting all data values obtained via this test method. Please note that only one Solar Reflectance measurement is reported per Sample Batch or array. This averaged value is calculated using the Test Method #1 Excel tool. Please contact info@coolroofs.org to receive the Excel tool that calculates the standard error and records the locations of measurements for this test method.

If testing is conducted using the Tile Template Method, the AITL must use the template provided in Appendix A of ANSI/CRRC S100. The AITL should note the placement of the template on the back or sides of each Specimen to ensure the template is placed in the same location for aged testing. The AITL must provide the CRRC with an Excel file documenting all data values obtained via this test method. Please contact info@coolroofs.org to receive the Excel tool for use with this test method.

When testing is conducted using ASTM E1918 - Standard Test Method for Measuring Solar Reflectance of Horizontal and Low-Sloped Surfaces in the Field, the AITL must provide the CRRC with an Excel file documenting all data values obtained via this test method. Please note that only one average Solar Reflectance measurement is reported per Sample Array. This averaged value is calculated using the ASTM E1918 Excel tool. Please contact the CRRC at info@coolroofs.org to obtain a copy of the Excel tool.

2.2.10 Photographic Documentation

Effective July 1, 2018, AITLs are required to photograph Specimens during initial and aged testing of all products undergoing the process of obtaining a CRRC product rating. The photographs shall be uploaded to the CRRC Online Rating Portal, along with the initial test results and the aged test results. See Appendix 4 of this program manual for details.

2.2.11 Weathering Tests

Accredited Independent Testing Laboratories are also responsible for conducting tests to determine the Aged Radiative Properties of Roofing Products, in accordance with sections 2.2.4 and 2.2.5 of this program manual. Accredited Independent Testing Laboratories must forward test Specimens (supplied by the Licensee) for weathering exposure directly to an Approved Test Farm after testing for Initial Radiative Properties (see below exception for products tested in accordance with ASTM E1918).

Test Specimens must be sent to the test farm no later than twenty-eight (28) calendar days prior to the next test farm placement date to ensure that the Specimens reach the test farm in time for that placement. Exposures will begin on the first day of every other month throughout the year, beginning with January 1. The test farm will conduct weathering of the Specimens in accordance with ASTM G7 - Standard Practice for Atmospheric Environmental Exposure Testing of Nonmetallic Materials. All Specimens are exposed with plywood backing material of the Test Farm's choice. Specimens shall be mounted in accordance with R.S.2.6(D) of ANSI/CRRC S100. See the CRRC Product Rating Procedures in Appendix 4 for more detailed information.

After testing product Samples for Aged Radiative Properties, AITLs are responsible for holding the weathered Specimens for a period of 90 calendar days or until the rated Aged Radiative Properties are approved by the CRRC before releasing the Specimens to the Licensee. The AITL must use the most current test method applicable to the Roofing Product type for measuring the Solar Reflectance and Thermal Emittance of aged products.

All AITLs, AMTLs, and Approved Test Farms shall adhere to select sections of ASTM G147 for the proper handling of weathered product Samples, in accordance with R.S.2.6 of ANSI/CRRC S100 and section 2.5.2 of this program manual.

2.3 Special Requirements for Approved Manufacturer Testing Laboratories

All AMTLs shall be subject to the provisions contained in sections 2.2, 2.2.1, 2.2.2, and 2.2.6 of this program manual, and the provisions that are contained in the following subsections:

- (A) All AMTLs shall participate in the Interlaboratory Comparison Study upon CRRC request, in accordance with section 2.2.2 of this program manual. Approved Manufacturer Testing Laboratories will be responsible for testing only their respective product type from the Sample set.
- (B) All AMTLs shall submit proof to the CRRC that the following procedures are in place:
 1. Written procedures for the operation of any CRRC approved test methods for which the laboratory seeks accreditation.
 2. Written training records of laboratory personnel who can perform tests and who report results from those tests.
 3. System for documenting and retaining testing records.
 4. System for calibrating any and all equipment used to generate Thermal Emittance and Solar Reflectance measurements.
 5. System for storing retained Specimens of all materials tested for color properties for a period of three years.

2.3.1 Renewal Requirements for Approved Manufacturer Testing Laboratories

An AMTL shall submit payment of the annual renewal fee to renew its participation with the CRRC. See www.coolroofs.org for the list of renewal fees.

2.4 Special Requirements for Accredited Independent Testing Laboratories

An AITL shall demonstrate that it meets the CRRC's requirements through submission of the following information at the time of application to become an AITL:

- (A) Evidence of accreditation by an official accreditation body as complying with the International Standard ISO 17025.
- (B) A listing of test methods that the accrediting body has found the AITL capable of performing for the CRRC Roof Rating Program.
- (C) Maintain at all times all tests on the current ISO 17025 scope of accreditation that the Accredited Testing Laboratory will perform for the CRRC Roof Rating Program.
- (D) Notify the CRRC immediately if the Accredited Testing Laboratory's ISO 17025 scope of accreditation changes.
- (E) An AITL must provide a statement of independence that shows it has no significant ownership or commercial interest in a supplier or Roofing Product company and is not owned by such a company.

2.4.1 Renewal Requirements for Accredited Independent Testing Laboratories

To renew annual participation in the Roof Rating Program, an AITL shall provide a copy of its current ISO 17025 scope of accreditation to the CRRC. The scope must list the CRRC-approved test methods the AITL performs for the CRRC Roof Rating Program, along with payment of the renewal fee. Renewal occurs on an annual basis. See www.coolroofs.org for the list of renewal fees.

2.5 Requirements for Test Farms

2.5.1 Test Farm Application Requirements

A test farm shall demonstrate that it meets the CRRC's requirements through submission of the following information at the time of application to become an Approved Test Farm:

- (A) A completed CRRC application and Test Farm Agreement
- (B) Payment of the required fee;
- (C) Evidence of accreditation by an official accreditation body as complying with ISO 17025.
- (D) A test farm must have exposure locations as specified in R.S.2.6 of ANSI/CRRC S100.

- (E) A list of test methods on its current ISO 17025 scope of accreditation that the test farm will perform for the CRRC Roof Rating Program.
- (F) A test farm must provide a statement that shows it has no significant ownership or commercial interest in a supplier or Roofing Product company and is not owned by such a company.
- (G) The test farm must not be a CRRC AITL or an affiliate of a CRRC AITL.
- (H) A test farm that measures colorimetry must participate in the Interlaboratory Comparison Study upon CRRC request, in accordance with section 2.2.2 of this program manual. The test farm will be responsible for testing only colorimetry of applicable products in the Sample set.

2.5.2 Product Weathering Exposure and Removal Requirements

Product weathering exposure and removal requirements, which shall include Specimen mounting, exposure, and removal, shall be in accordance with R.S.2.6 of ANSI/CRRC S100 and the CRRC Product Rating Procedure Details in Appendix 4 of this program manual.

Test farms shall notify the CRRC within 30 calendar days if Specimens have been pulled before the official three-year exposure completion date.

Effective July 1, 2018, test farms are required to photograph Specimens during three-year weathering at each Test Farm Site. The photographs shall be sent to the CRRC. See Appendix 4 of this program manual for details.

2.5.3 Renewal Requirements for Test Farms

To renew annual participation in the Roof Rating Program, a test farm shall provide a copy of its current ISO 17025 scope of accreditation. The scope must list the CRRC-approved test methods the test lab performs for the CRRC Roof Rating Program, along with payment of the renewal fee. Renewal occurs on an annual basis. See www.coolroofs.org for the list of renewal fees.

2.6 Requirements for Approved CRRC Rapid Ratings Laboratories

A CRRC Rapid Ratings Laboratory is authorized to conduct the Practice for Laboratory Aging of Roofing Materials in order to obtain simulated aged Radiative Property values for CRRC product ratings (i.e. Rapid Ratings).

- (A) An approved CRRC Rapid Ratings Laboratory must be a CRRC-approved AITL or test farm. ASTM D7897 shall be included and maintained on the

AITL or test farm's ISO 17025 scope of accreditation.

- (B) To implement ASTM D7897 as part of the CRRC's Rapid Rating program, at least one employee of the Laboratory must participate in a CRRC Rapid Ratings training workshop.
- (C) A laboratory conducting the Practice for Laboratory Aging of Roofing Materials for the Rapid Ratings Program shall provide the CRRC with the name and contact information of the staff person within the testing laboratory who participated in a CRRC Rapid Ratings training workshop. This person shall be responsible for supervising or performing the Practice for Laboratory Aging of Roofing Materials for Rapid Ratings at the laboratory (i.e. Responsible Person).
- (D) The laboratory shall notify the CRRC within 10 business days of any personnel changes as they pertain to the Responsible Person(s). To maintain approval to be a CRRC Rapid Ratings Laboratory, the laboratory must retain at least one Responsible Person to supervise or perform the practice and certify test results.

CHAPTER 3.0 CRITERIA FOR PRODUCT RATING AND ROOFING LICENSEES

3.1 General

To obtain or maintain an active status as a CRRC Licensee or CRRC Rated Roofing Product, the Licensee shall submit the required applications and agreements to the CRRC, and pay the required fees. The Licensee shall comply with all the conditions and criteria of this chapter and all applicable requirements of the CRRC Roof Product Rating Program, including payment of the annual renewal fees.

A Licensee, as governed by the CRRC Licensee Agreement, shall make no representation that it is approved or certified by the CRRC or that the rated Roofing Product is approved or certified by the CRRC. The CRRC does not certify or approve products.

3.2 Compliance with Criteria and Conditions

Compliance by a CRRC Licensee with all the criteria and conditions of the CRRC Roof Product Rating Program shall be subject to review by the CRRC at any time.

3.3 Licensee's Representative

A CRRC Licensee shall designate one or more individuals to be responsible for proper labeling of CRRC Rated Roofing Products. The Licensee shall be responsible to the CRRC for updating the information regarding the responsible individual(s). The notice of an update will include the name and address of the Manufacturer, and will list the licenses, the Manufacturer identification number, and the CRRC Rated Roofing Product identification numbers that are affected by the update.

3.4 Quality Control

CRRC Licensees shall have an appropriate quality control plan in place that ensures its Roofing Product(s) maintain Radiative Properties within ± 0.05 of those listed for that product(s) on the CRRC Rated Roof Products Directory (i.e. values obtained through testing). A Licensee shall designate at least one employee as the quality control manager at each plant, and shall provide the CRRC with the name and contact information for each of these individuals.

All quality control records and the quality control plan shall be made available to the CRRC upon written request.

3.5 Initial and Aged Testing Requirements

All test Specimens shall be submitted to a CRRC AITL for Initial Radiative Properties testing. Tests and weathering exposure shall be performed at the expense of the applicant. Upon completion of initial testing, all test Specimens, with the exception of Color Family Additional Elements, shall be sent by the AITL to an Approved Test Farm where they shall undergo weathering exposure for three (3) years according to the provisions set forth in Chapter 2.0 of this program manual, after which they shall be retested by an AITL in order to determine the Aged Radiative Properties. See Appendix 4 of this program manual for more detailed information.

The Licensee shall be responsible for the selection, sampling, and labeling of Roofing Products, components or materials that go through testing for a CRRC product rating according to the provisions set forth in the following sections 3.5.1 through 3.5.7 of this program manual:

3.5.1 Standard Production Line Roofing Products

Except Variegated Products (see section 3.5.5) and Aggregate Roofing Products (see Appendix 7)

- (A) Specimen Selection: Specimen selection shall be in accordance with R.S.3.2(A) of ANSI/CRRC S100 with exception of the following:

1. Profiled metal Roofing Products: Profiled metal Roofing Products shall be rated using flat Specimens of the same color and material. Ratings for these Samples may be applied to Profiled products.
2. Tile Products: Tile products shall be selected in accordance with R.S.3.2(A) of ANSI/CRRC S100. Tiles shall be flat, unless only Profiled products are available. For Tile blend assemblies that are made up of two or more colors, each color must be tested and rated as an individual product. Each color will appear on the CRRC Rated Roof Products Directory as a unique product. Tile blend ratings will be determined by calculating a weighted average of the colors in each particular blend.
3. Directionally Reflective Materials: Directionally Reflective Materials shall adhere to the size requirements of standard products set forth in Appendix 4 of this program manual and R.S.3.2 of ANSI/CRRC S100.

(B) Specimen Preparation: Specimen preparation shall be in accordance with R.S.3.2(B) of ANSI/CRRC S100.

Advisory Note: if a CRRC Application ID exists for the product in the CRRC Online Rating Portal, the Application ID may be included in the Specimen identification.

(C) Substrate: The Licensee shall be responsible for ensuring that test Specimens are prepared on the appropriate substrate in accordance with R.S.3.2(C) of ANSI/CRRC S100.

1. Liquid-Applied Roof Coatings:
 - i. Liquid-Applied Roof Coatings are applied to a standard aluminum substrate as defined in R.S.3.2(C) of ANSI/CRRC S100. Liquid-Applied Roof Coatings may also be applied to a Rough Substrate in accordance with the Dual Rating procedure. See section 3.5.4 of this program manual and Appendix C of ANSI/CRRC S100 for more information.
 - ii. For Liquid-Applied Roof Coatings designed for application to a specific substrate, the Manufacturer can choose to use an alternative substrate to the default bare aluminum panel. The Manufacturer

shall supply the substrate to the AITL along with instructions on how to properly apply the coating. A description of the alternative substrate must be included in the product rating application and test results.

- iii. If Liquid-Applied Roof Coating Specimens are prepared on a standard aluminum substrate by the Licensee prior to shipment to the AITL, the Licensee shall submit one unprepared Standard Substrate to the AITL, in addition to the test Specimens, for Thickness testing in accordance with Section 2.2.7 of this manual.

2. Non-Variegated Roofing Products: Non-Variegated Roofing Product Samples need not be applied to a substrate. Non-Variegated products may include, for example, Single-Ply Membranes, factory-coated metal, non-Variegated Stone-Coated Metal, non-Variegated asphalt shingles and cap sheets.

3. Factory-Applied Roof Products: The Licensee shall be responsible for ensuring that test Specimens are prepared on the appropriate substrate in accordance with R.S.3.2(C) of ANSI/CRRC S100.

(D) Radiative Properties Reporting:

The Rated Radiative Properties of test Specimens shall be reported according to the following provisions:

1. Initial Rated Radiative Properties shall be the arithmetic average of the initial test results of the Specimens from Batches A and B.
2. Aged Rated Radiative Properties shall be the arithmetic average of the aged test results of each of the nine (9) product Specimens that undergo aging exposure. See section 3.5.6 for Rapid Ratings and Appendix 4 of this program manual for products tested in accordance with E1918.
3. In the event that a test Specimen is Uncharacteristically Damaged in transit to the test farm or during weathering exposure to a degree that its Radiative Properties cannot be accurately measured or a Specimen is Incorrectly Exposed, it shall be removed from the calculation of the Aged Radiative Properties. As a result of such an occurrence, the Aged Rated Radiative Properties shall be reported as the arithmetic mean of the averaged results from each Test Farm Site.

Up to two product Specimens per Test Farm Site shall be permitted to be discarded if Uncharacteristically Damaged or Incorrectly Exposed. Should all three Specimens from one Test Farm Site be Uncharacteristically Damaged or Incorrectly Exposed, the Licensee shall submit new product Specimens and start the rating process over, which shall include initial testing, exposure at all three Test Farm Sites, and aged testing.

In the event that all three Specimens from one Test Farm Site are Uncharacteristically Damaged or Incorrectly Exposed and retesting is required, the product is permitted to be listed on the CRRC Rated Roof Products Directory until retesting is completed. Retesting includes taking new initial measurements as well as going through the three-year exposure process to obtain aged ratings. If the new initial ratings differ from the original initial ratings by no more than ± 0.05 , then the initial ratings on the CRRC Rated Roof Products Directory will be updated to reflect the new initial ratings. The Licensee shall be responsible for ensuring that CRRC Labels and any reference to the original initial ratings are appropriately updated based on the new initial ratings. If the CRRC has not received a retesting submission within six (6) months, the product will be removed from the CRRC Rated Roof Products Directory, and the Licensee will be notified.

All other conditions of damage will be assumed to be outside of the intent and application of “Uncharacteristically Damaged” or “Incorrectly Exposed.” Should all three Specimens from one test farm be rendered unusable from damage outside of what is defined as Uncharacteristically Damaged or Incorrectly Exposed, the Technical Committee shall review the case and provide a recommendation to the Board on whether the product needs to go through the rating process again. The Board shall take appropriate actions that may include removal of the product from the CRRC Rated Roof Products Directory, the Licensee would be required to start the rating process over if a rating is desired. Alternatively, the Licensee may elect to start the product rating process over again by having a new product Sample tested in advance or in place of the Board’s evaluation.

(E) Compound Ratings

1. Single-Ply Products: In order for a Single-Ply product to qualify for a Compound Product Rating for Solar Reflectance and Thermal Emittance, the product with the thinnest overall Thickness must

be tested. If a Licensee has multiple Single-Ply products with the same surface formulation but varying backing Thicknesses, the Solar Reflectance and Thermal Emittance ratings for the thinnest of these products may be applied to these other products.

2. Asphalt Shingle and Stone-Coated Metal Products: If a Licensee has multiple shingle or Stone-Coated Metal products with the same exposed color blend granule formulation, the Solar Reflectance and Thermal Emittance ratings for the tested product may be applied to these other products. The Licensee submitting the shingle or Stone-Coated Metal product for a rating must declare as part of their application any differences such as varying granule distributions, the non-exposed shingle or Stone-Coated Metal system components and/or design features.

For Variegated shingle or Stone-Coated Metal products using the mono-color calculation method to determine the Radiative Properties, each granule color used in the blend must be tested and rated as an individual product (see Appendix 2). Each color will be submitted to the CRRC Online Rating Portal as a unique product, but will not be publicly displayed on the CRRC Rated Roof Products Directory. Blended granule product ratings will be determined by calculating a weighted average of the colors in a particular blend.

3. Granule-Surfaced Roll Products and Modified Bitumen: If a Licensee has granule-surfaced roll products with granules that have the same color blend formulation and size, Solar Reflectance, and Thermal Emittance, and/or factory applied coatings that have the same coverage rate and formulation, the Solar Reflectance and Thermal Emittance ratings for the tested product may be applied to these other products. The Licensee submitting the granule-surfaced roll product for a CRRC product rating must declare as part of their application any differences in the non-exposed system components or design features.

For Variegated granule-surfaced roll products using the mono-color calculation method to determine the Radiative Properties, each granule color used in the blend must be tested and rated as an individual product (see Appendix 2). Each color will be submitted to the CRRC Online Rating Portal as a unique product, but will not be publicly displayed on the CRRC Rated Roof Products Directory. Blended granule product ratings will be determined by calculating a weighted average of the colors in a particular blend.

4. **Polymer Molded Shake/Slate/Tile Shaped Products:** In order for a polymer product to qualify for a Compound Product Rating, the shape with the lowest Solar Reflectance value will be used for the CRRC product rating, as long as all other shapes share the same surface formulation. The Licensee will submit nine (9) Specimens of each shape for initial rating. All shapes must be initially measured by an AITL to determine the lowest reflectance, and the shape with the lowest reflectance will be used for reporting the CRRC initial and aged values. The Profiled product with the lowest Solar Reflectance will be sent to weather at the test farm. Any additional shapes that the Licensee wishes to add to the rating after initial approval must undergo initial Solar Reflectance testing to show that their Solar Reflectance value is not less than the approved representative shape.
5. **Wood Roofing Products:** In order for cedar Roofing Products to qualify for a Compound Product Rating, all geometries (i.e. type of cut) must be initially tested. The Licensee will submit nine (9) Specimens of each geometry for initial rating. All geometries must be measured by an AITL to determine the lowest Solar Reflectance and the shape with the lowest reflectance will be used for reporting the CRRC initial and aged values. The product geometry with the lowest Solar Reflectance will be sent to weather at the test farm.

3.5.2 Color Family Groups and Representative Elements

(A) Specimen Selection and Preparation

Specimen selection, preparation, and Radiative Properties reporting shall be in accordance with R.S.3.3 of ANSI/CRRC S100.

(B) Radiative Properties Reporting:

- Radiative Properties reporting shall be in accordance with R.S.3.3(D) of ANSI/CRRC S100 and the following requirements:
1. Initial Rated Radiative Properties reported on the Product Rating Application and determined by the average of the tests conducted on Specimens from Batches A and B, shall be equal to or greater than the default value for the associated Color Family as described in Appendix 5 of this program manual.
 2. Hunter “L,” “a,” and “b” measurements shall be taken and reported on the initial test results in accordance with ASTM E805, Section 9 (Color Measurement Equipment Specification: 0°/45° or 45°/0° (illuminant angle/viewing angle) geometry with 10° standard observer, D65 Illuminant). One measurement shall be conducted on one product Specimen from Batch A and one product Specimen

from Batch B. The average measurement value for each coordinate (“L,” “a,” and “b”) shall be reported in the CRRC Online Rating Portal. The color coordinates shall be within the tabular color coordinate ranges for the associated color families as shown in Appendix 5 of this program manual.

Advisory Note: Colorimetry measurements may be made by an AITL, AMTL, Approved Test Farm or CRRC Licensee that is rating a Color Family Element. Should color differences between Batch A and Batch B exceed $\pm 0.5 \Delta L$, Δa , or Δb , the Licensee must be contacted to determine if the average values of the color readings between Batch A and B should be used, or if resampling is necessary.

3. The reported Aged Rated Radiative Properties shall be no higher than the arithmetic average of the aged test results of each of the nine (9) product Specimens that undergo aging exposure or equal to the initial default values for the Color Family Group, whichever is lower.
4. In the event that a Specimen is Uncharacteristically Damaged during weathering exposure, it shall be removed from the calculation of the Aged Radiative Properties. As a result of such an occurrence, the reported Aged Rated Radiative Properties shall be no higher than the arithmetic average of the averaged results from each Test Farm Site. See section 3.5.1(D) of this program manual for more information.

See Appendix 5 of this program manual for more detailed information about the Color Family Program.

3.5.3 Color Family Additional Elements

(A) Specimen Selection:

Six (6) Specimens shall be randomly selected and sent to an AITL for Radiative Properties testing for each Color Family Additional Element to be added to an existing Color Family Group.

(B) Specimen Preparation: (including size, Batch, number of Specimens, identification, substrate, and Thickness)

Test Specimens shall be grouped into two sets as follows:

- 1) three (3) Specimens from one Batch, and
- 2) three (3) Specimens from a second Batch.

Test Specimens shall be labeled with the necessary identification information by Batch and Specimen within each Batch. Each Specimen must be at least 155 square centimeters (24 square inches) in size.

(C) Radiative Properties Reporting:

The Rated Radiative Properties of Color Family Additional Elements shall be reported according to the following provisions:

1. Initial Rated Radiative Properties reported to the CRRC shall be no higher than the average of the initial test results of the Specimens from Batches A and B.
2. Hunter “L,” “a,” and “b” measurements shall be taken and reported on the initial test results in accordance with ASTM E805, Section 9 and the protocol described in section 3.5.2. One measurement shall be conducted on one product Specimen from Batch A and one product Specimen from Batch B. The average measurement value for each coordinate (“L,” “a,” and “b”) shall be reported in the CRRC Online Rating Portal. The color coordinates shall be within the tabular color coordinate ranges for the associated color families as shown in Appendix 5 of this program manual.

Advisory Note: Colorimetry measurements may be made by an AITL, AMTL, Approved Test Farm, or CRRC Licensee that is rating a Color Family Element.

3. No Aged Radiative Properties testing is performed for Color Family Additional Elements. The Aged Rated Radiative Properties shall be identical to what is reported for the Representative Element of the Color Family Group; either the initial Color Family default values or the actual aged rated values of the Representative Element, whichever is lower, will be used.

See Appendix 5 for more detailed information about the Color Family Program.

3.5.4 Dual Ratings for Liquid-Applied Roof Coating Products

Effective September 1, 2021, Liquid-Applied Roof Coating products have the option of obtaining ratings over both a smooth and Rough Substrate. Manufacturers may test their products over a Smooth Substrate, Rough Substrate, or both. Testing over a Rough Substrate shall be conducted per the specification described in Appendix C of ANSI/CRRC S100.

All new Liquid-Applied Roof Coating product applications submitted on or after the effective date are required to use the Dual Rating Product Label.

Liquid-Applied Roof Coating products that were submitted prior to the effective date must transition to the Dual Rating Product Label by September 1, 2022. After that date, Manufacturers must cease use of any other

CRRC Rated Product Labels on Liquid-Applied Roof Coating products.

After the effective date, Liquid-Applied Roof Coating products on the CRRC Rated Roof Product Directory will display a suffix indicating whether it was tested over a Smooth Substrate or Rough Substrate. Liquid-Applied Roof Coatings products that have been tested over both will display as two separate lines in the CRRC Directory.

For products with ratings over both smooth and Rough Substrates, the CRRC initial rating and annual renewal fees for the second rating will be 50% of the standard fee amount.

3.5.5 Variegated Products That Are Tested Under CRRC-1 Test Method #1

Specimen selection, preparation, testing, and Radiative Properties reporting of Variegated roof products shall be conducted in accordance with R.S.3.4 of ANSI/CRRC S100 and the following provisions.

To determine if a Roofing Product is Variegated, the AITL shall take a series of five (5) Solar Reflectance measurements approximately equidistant along a diagonal axis of the Specimen. When any of the five Solar Reflectance measurements varies by more than 0.05 from the arithmetic average of all five measurements, then the product will be deemed to be a Variegated product. See R.S.2.2(C)(a) of ANSI/CRRC S100.

(A) Specimen Selection:

For Variegated products that are not shingles, not Stone-Coated Metal, and not Tiles that are tested under CRRC-1 Test Method #1, Specimens shall be randomly selected from routine production and sent to an AITL for testing. These Specimens shall be grouped into three (3) sets:

1. Three (3) Specimens from Batch A;
2. Three (3) Specimens from Batch B;
3. Three (3) Specimens for which each of the two Batches shall be represented.

This results in a total of four Specimens from one Batch and five from the other.

Advisory Note: Tile is tested with either a modified version of CRRC-1 Test Method #1 or the Tile Template Method, which specifies Specimen size requirements.

(B) Specimen Preparation: (including size, Batch, number of Specimens, identification, substrate, and Thickness):

1. If a Licensee has multiple shingle, Stone-Coated Metal, or granule-surfaced roll products with the same exposed color blend granule formulation, the

Solar Reflectance and Thermal Emittance ratings for the tested product may be applied to these other products. The Licensee submitting the shingle, Stone-Coated Metal, or granule-surface rolled products for a CRRC product rating must declare as part of their application any differences such as varying granule distributions, the non-exposed shingle system components or design features. Aged values can be determined using the equation in Appendix 2 of this program manual.

2. For Polymer Slate/Shake/Tile Shaped Products, if a Licensee has multiple Variegated polymer shaped products with the same surface formulation, the Solar Reflectance and Thermal Emittance ratings for the lowest rated product may be applied to the other shapes. The lowest reflectance Profiled product will be sent to weather at the test farm.

3.5.6 Requirements for CRRC Rapid Ratings

CRRC Rapid Ratings is an optional CRRC product rating process based on interim laboratory-aged values for roofing materials using the Practice for Laboratory Aging of Roofing Materials, as specified in ASTM D7897. These values are displayed on the CRRC Rated Roof Products Directory and on CRRC product labels until products have completed the three-year weathering process and three-year aged ratings become available.

The following criteria shall be met to determine CRRC Rapid Ratings:

- (A) **Laboratory qualifications:** Rapid Ratings shall be performed by an approved CRRC Rapid Ratings Laboratory.
- (B) **Specimen qualifications:** Each test Specimen must meet the shape requirements of the Practice for Laboratory Aging of Roofing Materials. The size of test Specimens shall comply with section R.S.2.7(A) of ANSI/CRRC-S100 (10 centimeters by 10 centimeters (3.94 inches by 3.94 inches)). For coating products applied to a Rough Substrate, please follow the Specimen Preparation Instructions in Appendix C of ANSI/CRRC S100 of this manual. For Variegated products please see Appendix B of ANSI/CRRC S100.
- (C) **Specimen quantity:** For monochrome products, three Specimens of each product shall be used (in addition to the Specimens needed for initial and three-year aged testing). For Variegated products, nine (9) Specimens of each product are required (in addition to the Specimens needed for initial and three-year aged testing).

Advisory Note: Initial and Aged Radiative Properties shall be measured in accordance with sections 2.2.4, 2.2.5, 3.5, and Appendix 4 of this program manual.

(D) **Laboratory aging:** The practice shall be conducted in accordance with the Practice for Laboratory Aging of Roofing Materials. Also see section R.S.2.7 of ANSI/CRRC S100. For Variegated products please see Appendix B of ANSI/CRRC S100.

(E) **Laboratory-aged radiative measurements:** Following application of the Practice for Laboratory Aging of Roofing Materials by an approved CRRC Rapid Ratings Laboratory, the Solar Reflectance and Thermal Emittance of each Specimen shall be measured by an AITL in accordance with sections 2.2.4 and 2.2.5 of this program manual. These two entities can be the same laboratory. For Variegated products please see Appendix B of ANSI/CRRC S100.

(F) **Calculation of laboratory-Aged Radiative Properties:** The laboratory-aged Solar Reflectance and Thermal Emittance values are obtained by taking the mean of these measured properties from the three (3) laboratory-aged Specimens.

(G) **Reporting of laboratory-Aged Radiative Properties:**

1. The CRRC Rated Roof Products Directory and CRRC Labels may report laboratory-Aged Radiative Properties for any product that has begun, but has not yet completed, three-year weathering at an Approved Test Farm in accordance with section 3.5 of this program manual. Laboratory-Aged Radiative Properties will be identified as 'CRRC Rapid Rating' values in the Rated Roof Products Directory and on CRRC Labels. Once the product has completed the three-year weathering process, and three-year aged values become available, the recorded aged values will replace the interim Rapid Ratings on the Products Directory and on CRRC Labels.
2. Also see R.S.2.7(F) of ANSI/CRRC S100.

3.5.7 Products Tested Under ASTM E1918

ASTM E1918 is a CRRC-approved test method for measuring the Solar Reflectance of Roofing Products. Details covering the implementation of the method are described below.

(A) Specimen Selection:

Specimen selection shall be in accordance with R.S.3.4(A) of ANSI/CRRC S100.

Exception: Aggregate Roofing Product Samples shall be randomly selected from routine production. Only three (3) test Specimens per Sample are required for assembly and testing. See below for Specimen preparation requirements.

(B) Specimen Preparation (including size, Batch, number of Specimens, identification, substrate, and Thickness):

1. One product Sample shall be comprised of three test Specimens. Test Specimens shall meet the following requirements:
2. Be at least 4 meters by 4 meters (13.1 feet by 13.1 feet) in size as specified in ASTM E1918;
3. Be prepared on site at each test farm exposure location (one Specimen per test farm);
4. Be constructed under direction of the Licensee;
5. Be in conformance with CRRC policy on the exposure of low-slope materials (see R.S.2.6(D) of ANSI/CRRC S100; and
6. Be constructed in accordance with the Manufacturer's recommendations (e.g., appropriate substrate, application rate) and in a manner that will not impede proper drainage.

The Licensee is responsible for ensuring that the test Specimens meet the above requirements.

(C) Radiative Properties Reporting:

Solar Reflectance measurements taken in accordance with ASTM E1918 shall be reported to the CRRC through the Online Rating Portal. The provided Excel reporting tool must be completed and uploaded to the Online Rating Portal along with the test results. Thermal Emittance measurements for products other than roofing aggregate shall be made in accordance with section 2.2.5 of this program manual.

Advisory Note: The CRRC provides an Excel tool that facilitates ASTM E1918 measurement reporting and documents the location and conditions under which the measurements were taken. Please contact info@coolroofs.org to receive a copy of these resources.

Initial Solar Reflectance shall be measured in situ on only one of the three (3) test Specimens at one Test Farm Site. Measurements shall be made by an AITL.

Aged Solar Reflectance is measured in situ at the Test Farm Site to avoid disturbing the Specimens after the three-year weathering process. Measurements are taken on each test Specimen at each of the three (3) test farm locations. See section 2.2.10 of this program manual for more information about aged testing.

3.5.8 Special Processes

The CRRC may approve other methods of Sample selection on a case by case basis for special processes or circumstances.

3.5.9 Photographic Documentation

Effective July 1, 2018, AITLs and test farms are required to photograph Specimens during initial testing, three-year weathering, and aged testing of all products undergoing the process of obtaining a CRRC product rating. The photographs shall be submitted to the CRRC along with the initial test results and aged test results. See Appendix 4 of this program manual for details.

3.6 Validation Testing of Rated Products

The purpose of the Validation Testing Program is to verify the accuracy of actively rated product ratings and to maintain the credibility of the CRRC Rated Roof Products Directory, in accordance with the CRRC Validation Testing Procedures (see Appendix 3 of this program manual).

Products with an active CRRC rating are required to have passed Validation Testing in order to remain active on the CRRC Rated Roof Products Directory, with the exception of Reference and Blend Assembly products. Reference and Blend Assembly products are excluded from Validation Testing because they are subjected to Validation Testing through the parent product.

Actively rated products are due for Validation Testing seven (7) years after initial approval of the ratings and every seven (7) years thereafter. Products may be tested before seven (7) years if Challenge Testing is invoked (see Challenge Testing, Appendix 3).

When a product is due for Validation Testing, Licensees must submit a decision on how to proceed at the beginning of that year. Licensees must indicate if a product will proceed with testing, voluntarily terminate, or proceed with a Formula Change or Retesting application to replace the existing product.

For products proceeding with Validation Testing, the CRRC will inform the Licensees which AITL will be conducting testing. The Licensee shall send product Samples (test specimens) undergoing Validation Testing directly to the selected AITL.

Licensees must provide information to the CRRC detailing how the Samples were produced. Samples should be uniquely identifiable, whether through the Sample Tag or labeling of the individual Sample(s).

If applicable, Licensees must provide a brief instruction document outlining how to prepare the Sample(s). This instruction document must be supplied to the AITL.

Products are considered to have **failed** a Validation Test if:

1. The measured Solar Reflectance as reported by the AITL for the Validation Testing Program

differs by more than ± 0.05 from the initial rated Solar Reflectance, or

2. The measured Thermal Emittance as reported by the AITL for the Validation Testing Program differs by more than ± 0.05 from the initial rated Thermal Emittance for products with an initial emittance of less than or equal to 0.30 or differs more than ± 0.10 for products with an initial emittance greater than 0.30.

If the product fails two (2) separate Validation Tests, the product is deemed out of compliance with the requirements of the CRRC Roof Product Rating Program, and the Product Rating will be removed from the CRRC Rated Roof Products Directory on December 31st of the year that the product was selected for Validation Testing.

Licensees are responsible for shipping product Samples to the AITL, giving the AITL enough time to test and submit Validation Test results to the CRRC by the end of the year, including enough time for second tests if necessary. Failure to pass Validation Testing by December 31 can result in the product being permanently removed from the CRRC Rated Roof Products Directory.

See Appendix 3 of this program manual for more detailed information regarding Validation Testing.

3.7 Product Rating Authorization Procedures

(A) A Manufacturer of components or materials that determines the Radiative Properties of final Roofing Products may obtain Tested Radiative Properties on such components and materials in accordance with the provisions in section 3.5 of this program manual. Manufacturers of final Roofing Products incorporating such tested components and materials may use the other Licensee's test results in applications to their own final Roofing Products. The marketer of Privately-Labeled Roofing Products may similarly use the test results of the original Manufacturer to obtain CRRC product ratings for their own final Roofing Products. Any scenario wherein one rated product's rating relies on another rated product's rating through a Reference rating application, identical ratings values must be used for both the rated products on the CRRC Rated Roof Products Directory and the CRRC Label. If the product that is being Privately-Labeled is Terminated, all corresponding product ratings (i.e. Reference ratings) that rely on the original Manufacturer's rating will also be Terminated.

(B) General Licensee Procedures:

Except as described in section 3.7(A) of this program manual above, each Licensee shall obtain the measured Radiative Properties from a CRRC

Accredited Testing Laboratory for each rated Roofing Product. Those Tested Radiative Properties shall be obtained by complying with the applicable testing provisions of Chapter 3.0 of this program manual, and will be submitted by the AITL through the CRRC Online Rating Portal. The CRRC will notify the Licensee once it approves a product rating. A copy of the Notification of Product Rating will be made available to the Licensee on the CRRC Online Rating Portal. Any copy of the Notification of Product Rating certificate shall be reproduced in its entirety.

(C) Rating Acquisitions Procedures:

When a Licensee (Company A) acquires another Licensee (Company B) or their products and chooses to retain the product ratings under its own company name, Company A must submit new Product Rating Applications for each of Company B's active products in accordance with the procedures in section 3.8 of this program manual. The CRRC reserves the right to require that Company A resubmit products for initial testing, weathering, and aged testing if warranted.

Staff will work with the Licensee to ensure that the rated values for the new product listings are correct.

3.8 Product Rating Applications

(A) All product applications:

A Licensee applicant shall submit the following to the CRRC for each product for which it wishes to obtain CRRC product ratings:

1. Complete a product rating application on the CRRC Online Rating Portal.
2. Submit payment of the application fee.
3. Attach a Safety Data Sheet, product specification sheet, field application instructions, or other supporting documentation as applicable.
4. Assign a public contact for the CRRC Rated Roof Products Directory.
5. Assign the AITL and Test Farm who will handle testing and Sample exposure for the product.
6. Any other pertinent information relevant to the submission required by the CRRC.

3.9 Formula Change

A Formula Change is defined as a change in Radiative Properties of more than ± 0.05 from its initial values. Any CRRC Rated Roofing Product that undergoes a Formula Change shall obtain a new CRRC product rating and new CRRC Rating Authorization in accordance with the procedures as set forth in Chapter 2.0, section 3.5, and Appendix 6 of this program manual. Licensees may also choose to retest a rated product at any time, including a reformulated product that results in a change in Radiative Properties less than ± 0.05 from the initial values. See Appendix 3 of this program for more information about retesting as a result of Validation Testing failure.

(A) Formula Change or a Retested Product:

To rate a retested or reformulated product, the Licensee shall have an AITL submit new test results. The Licensee shall submit all other required fees and documentation, including completing a new product rating application via the CRRC Online Rating Portal that denotes that a reformulation or a retesting of a Roofing Product with an active CRRC rating has occurred. The replacement product shall receive a CRRC product ID number that consists of the ID number of the original formulation followed by a letter suffix. Any product referencing the original product will require authorization to reference the new product. When the replacement initial results have been approved by the CRRC, the Rated Radiative Properties for the retested Roofing Product and any associated Reference products shall be listed on the CRRC Rated Roof Products Directory, and the CRRC Label and the Notification of Product Rating shall be updated. The rating for the previous formulation will remain on the CRRC Rated Roof Products Directory until the Licensee chooses to have it inactivated. The Licensee shall discontinue labeling of any inactivated product.

3.10 Product Retesting Due to Test Method Changes

The CRRC periodically adopts new test methods or approves substantive changes to existing test methods. When these changes are adopted, some products with existing CRRC ratings may be required to be retested with new product Specimens using the new test method. The specific retesting requirements will vary depending on the test method adoption or change.

Appendix 9 of this program manual contains the technical guidelines used by the CRRC Technical Committee to consider a test method change as well as the Retesting Policy Guidelines used by the CRRC Board to determine retesting requirements.

3.11 Converting Standard Product to Color Family Product

If a Licensee elects to convert a standard Production Line Roofing Product into a Color Family Representative Element or Additional Element, the Licensee must submit a new product rating application, and an AITL shall submit the test results. The test results must include measurements of Hunter L, a, and b and Initial Radiative Properties and, if available, the Aged Radiative Properties. If the original test results for the standard product did not include colorimetry measurements, the Licensee must submit two (2) test Specimens from two (2) different Batches to be tested for colorimetry (Hunter L, a and b properties) by an AITL in accordance with ASTM E805, Section 9, as well as initial reflectance and emittance properties. These radiative values must be within the allowable ± 0.05 tolerance of the original standard product rating radiative values in order for the colorimetry values for these Specimens to be applied to the original standard product rating.

When the product application is completed, the Roofing Product listing will be updated on the CRRC Rated Roof Products Directory and the CRRC Label accordingly, such that the standard product listing is no longer on the CRRC Rated Roof Products Directory.

3.12 CRRC Label Requirements

A Licensee shall only use the CRRC Label for CRRC Rated Roofing Products in accordance with Chapter 4.0 of this program manual.

3.13 Confidentiality

CRRC product rating applications and test results shall be considered confidential and shall not be disclosed by the CRRC except pursuant to legal process or in the context of appeals, in which the Licensee will be notified.

3.14 Inactive Product Ratings

A CRRC Rated Roofing Product shall be removed from the CRRC Rated Roof Products Directory for any of the following reasons:

- (A) Product has been discontinued by the Manufacturer, meaning it is no longer in production or they no longer wish to maintain a CRRC product rating.
- (B) The product rating has been Terminated by the CRRC for any reason, including failure of Validation Testing or failure to comply with CRRC requirements.

Once a product rating is no longer active and listed on the CRRC Rated Roof Products Directory, the Licensee must

discontinue use of the CRRC Product Label and CRRC Rated Product Logo in all product packaging, marketing materials, product data sheets, and any and all other digital and print materials containing the CRRC Product Label and/or CRRC Rated Products Logo.

The Licensee must reapply to have that product reactivated and listed on the CRRC Rated Products Directory, unless the product was Terminated (see Appendix 6 of this program manual for more information). The Licensee must provide either a statement that the formula has not changed or re-test the product if the formula has changed.

When a product is moved to the Inactive Product Rating list before the aged testing has been conducted, the Licensee is not required to have the products age-tested by an AITL. However, if the Licensee chooses to undergo aged testing, the CRRC asks that the Licensee instruct the AITL to provide the results to the CRRC, which shall be included on the Inactive Product Rating list. Test farms shall notify the CRRC within 30 calendar days if products have been pulled before the three-year exposure process has fully completed.

CHAPTER 4.0 CRRC LABEL USE

4.1 General

Use of the CRRC Label, as governed by the CRRC Licensee Agreement, is permitted solely for products that meet the CRRC Roof Product Rating Program requirements and for which a Rating Authorization has been issued.

4.2 Licensed Use of the CRRC Label

The following requirements shall be met when using the CRRC Label:

- (A) The graphic format shall be as shown in the Licensee Agreement.
- (B) The CRRC Label shall be used only for Roofing Products that have been determined by the CRRC to meet the CRRC Rating Program requirements.
- (C) The CRRC Label shall be clearly visible and shall be placed on one or more of the following:
 - 1. The rated Roofing Product.
 - 2. The packaging, wrapping or container for the rated Roofing Product.

- 3. The bill of lading or other documentation that accompanies the delivery of the Roofing Product to the user.

- (D) The CRRC Label shall be displayed separate and apart from all other trademarks, brands, labels, symbols, and logos.
- (E) When displayed in marketing brochures and technical or specification information, the CRRC Label shall be placed adjacent to the Roofing Product specification or illustration of the Roofing Product that has received the CRRC product Rating Authorization.

4.3 Reproduction of Label

The CRRC will provide the label to the Licensee upon request. The CRRC Label is available in color, grayscale, and all white. Reproduction of the label shall meet the following requirements:

- (A) Not be smaller than the label, as indicated in the Licensee Agreement.
- (B) Must meet the same proportions as the minimum required dimensions if the label is re-sized.
- (C) Must not be revised or altered in any way, except for the insertion of the rated values, and must be displayed in the same form and color(s) as produced by the CRRC.
- (D) Include the necessary information as shown in the Licensee Agreement as well as the Solar Reflectance and Thermal Emittance values, determined in accordance with Chapters 2.0 and 3.0 of this program manual.

See the CRRC Product Label Guidance at coolroofs.org for more information.

CHAPTER 5.0 REVOCATION OR CLOSING FILES

5.1 Scope

The CRRC shall have the authority to revoke or modify for cause (including but not limited to imposition of further conditions) any license granted under the CRRC Roof Product Rating Program. "Cause" shall include:

- (A) Failure of the material to conform to the rating upon which the Rating Authorization was based.
- (B) Failure of the material, and/or method of manufacturing, to remain consistent.

- (C) Failure of the Licensed Party to comply with any condition or rule of the CRRC Roof Product Rating Program.
- (D) Any intentional misstatement made by the Licensed Party in the application or any knowingly inaccurate data submitted in support thereof.
- (E) Failure to comply with any provision in the Rating Authorization, Licensee Agreement, Licensed Test Farm Agreement, or Accredited Laboratory Agreements, including Laboratory CRRC Logo License Agreements.
- (F) Any other ground considered as adequate cause in the judgment of the CRRC whether of the same or a different type than listed above.

Upon revocation of the license, the Terminated Licensed Party must discontinue use of the CRRC Product Label, CRRC Rated Product Logo, CRRC Accredited Laboratory Logo, or CRRC Test Farm Logo, where applicable.

5.2 Reinstatement

- (A) Licensed parties that are Terminated as a result of nonpayment of annual CRRC renewal fees may be reinstated if the necessary fees are paid within the same calendar year. At the end of the calendar year, reinstatement is subject to item to item (B).
- (B) The submission for license reinstatement shall be in accordance with the requirements stipulated in Chapter 3.0 for Licensees or Chapter 2.0 of this program manual for accredited test farms and test labs.

5.3 Consultation

Prior to the CRRC acting on the closing of files, the holder of the CRRC license shall be given reasonable notice and an opportunity to be heard in accordance with section 6.2 of this program manual.

CHAPTER 6.0 COMPLAINTS

6.1 Purpose

These rules establish procedures for complaints regarding CRRC licenses and Roofing Product ratings.

6.2 Pre-Action Procedures

Any party shall be afforded the opportunity to discuss, clarify, and resolve disagreements with respect to cited disputes concerning actions by the CRRC or by a Licensed Party regarding licensure and labeling policies and procedures prior to that party submitting a complaint.

6.3 Submission

Any person may submit a written complaint to the CRRC. Complaints shall be directed to CRRC headquarters, and shall include the following information:

- (A) The name(s) and address(s) of the submitter(s), telephone, facsimile, and e-mail contact numbers,
- (B) A description of the complaint,
- (C) Relevant information to support the complaint, and
- (D) A filing fee to be determined by the CRRC Board. In the event of a complaint regarding inaccuracy of a product rating, the complainant shall pay a filing fee that includes the cost of obtaining and testing the product Sample.

The CRRC reserves the right to request further information or written clarification.

6.3.1 Notification

Upon receipt of the complaint, the CRRC shall forward a notice indicating receipt of the submission, an action plan that further identifies cost and timeline for resolving the complaint, and shall assign the submission a file number. Any Licensed Party who is the subject of the complaint shall be provided with a copy of the notice.

6.3.2 Review

The CRRC may take such action as it deems appropriate, in its sole discretion, to address complaints pertaining to the CRRC Roof Product Rating Program and participation thereof. In the event of a complaint regarding inaccuracy of a Licensee’s product rating, the CRRC will obtain a product Sample through the methods described in section 3.6 of this program manual, and shall perform testing in accordance with the Validation Testing procedures (see Challenge Testing, Appendix 3 of this program manual). In the event the product rating was inaccurate, the Licensee shall pay the CRRC the amount of the filing fee and the complainant shall have its filing fee refunded.

The complainant shall be notified of the CRRC’s resolution of the complaint.

6.3.3 Responsibility of Licensed Parties and Complainants

The Licensed Party and complainant shall keep a record of complaints made known to it relating to compliance with rating requirements and makes these records available to the CRRC when requested and:

- (A) Takes appropriate action with respect to such complaints and any deficiencies found in products that affect compliance with the requirements for CRRC rating;
- (B) Documents the actions taken; and
- (C) Informs the CRRC, without delay, of changes that may affect its ability to conform with the CRRC's requirements.

CHAPTER 7.0 APPEALS

7.1 General

Any Licensed Party (appellant) aggrieved by any determination by the CRRC pursuant to Chapter 5.0 of this program manual who chooses to appeal shall do so within 20 business days of the date of receipt of said written determination or order.

7.2 Submission

Appeals shall be submitted in writing, directed to the CRRC Board Chairperson, addressed to the CRRC headquarters, and shall include the following information:

- (A) The name and address of the appellant, telephone, facsimile, and email contact information, and the name and address of legal counsel if the appellant desires to have representation,
- (B) A description of the Roofing Product under appeal,
- (C) A description of the issue being appealed,
- (D) A statement of reasons for appeal,
- (E) Relevant evidence and supporting data or information, and

The CRRC reserves the right to request further information or a written clarification from the appellant, and shall extend the appeal review if, in the opinion of the CRRC, the content of the additional information or written clarification is of substance to warrant additional time.

7.3 Notification

Upon receipt of the appeal, the CRRC shall assign a file number. All future correspondence to and from the CRRC shall reference the file number. The appellant shall be notified of the convening of any associated hearing by the CRRC.

7.4 Appeal Review

The CRRC shall, upon receipt of a completed submission, evaluate the appeal and render a decision of the matters in dispute within 20 business days of receipt of the completed submission or within 20 business days of a hearing if one is convened. The decision to hold a hearing shall be at the discretion of the CRRC Board. The CRRC reserves the right to extend the time of review if the CRRC determines that there is sufficient cause. The CRRC shall notify the appellant of the CRRC's decision by certified mail, return receipt requested, or other

method, which provides evidence of, and a receipt for, delivery.

decision within 15 business days of the hearing or of the final written submission

CHAPTER 8.0 ARBITRATION

8.1 General

If the appellant disputes the decision of the CRRC under Chapter 7.0 of this program manual, the appellant has the right to appeal solely through arbitration. The appellant shall notify the CRRC of a request for arbitration in writing within 20 business days of receipt of the written appeal review decision. The request shall include the following information:

- (A) The name(s) and address(s) of the appellant(s), telephone, facsimile, and email contact information, and name and address of legal counsel if the appellant desires to have said representation,
- (B) A description of the Roofing Product under arbitration,
- (C) A description of the issue being arbitrated,
- (D) A statement of reason for the arbitration,
- (E) Relevant evidence and supporting data or information, and
- (F) A concise statement of its rebuttal position(s).

8.2 Arbitration Method

The arbitration shall consist of one of the following methods:

- (A) A single arbitrator selected jointly by the appellant and the CRRC to investigate and resolve the matter, or
- (B) The CRRC and the appellant shall use the American Arbitration Association's procedures for the selection of a single arbitrator from a list of seven candidates, with each party having the right to strike three.

8.3 Cost

The appellant shall be responsible for all time and expense costs incidental to the arbitration proceedings.

8.4 Hearing

The hearing may be conducted under the American Arbitration Association procedures for arbitration if requested by either party. Unless otherwise agreed upon by all parties, the arbitrator(s) shall issue a written

APPENDIX 1: DEVICES AND SERVICES TECHNICAL NOTE TN11-2*

* Please note that Appendix 1 includes an excerpt of Technical Note TN11-2. To view the document in its entirety, visit the Devices & Services Company website.



Devices & Services Company

10290 Monroe Drive, Suite 202 - Dallas, Texas 75229 USA - Tel. 214-902-8337 - Fax 214-902-8303

Web: www.devicesandservices.com – Email: sales@devicesandservices.com

D&S Technical Note 11-2

© D&S 2011

Model AE1 Emittance Measurements using a Port Adapter, Model AE-ADP

Introduction

Emittance measurements with the D&S model AE1 Emissometer require that the high and low emittance standards and the Sample to be measured be maintained at the same temperature. To achieve a uniform temperature the instrument is provided with a heat sink on which to mount the standards and the Sample. For materials that cannot be properly applied to the heat sink, or have low thermal conductivity, it is necessary to correct for the increased surface temperature of the Sample when exposed to the heated detector surface.



AE1 detector showing the diffuse black heated substrate and the sensing element (center)

Techniques for making these measurements are described in D&S Technical notes:

TN 79-17 Emissivity Measurements for In-Place Surfaces and for Materials with Low Thermal Conductivity

TN 81-2 Measurement of Emittance of Cylindrical Surfaces

TN 84-2 Emissometer Adapter Model AE-AD1

TN 04-1 Slide Method for AE Measurements

TN 10-2 Slide Method for High Emittance Materials with Low Thermal Conductivity

This note describes the use of a port adapter to make these and other measurements. Standard port adapters are available to measure Samples smaller than the 2 1/8 inch diameter of the detector port.

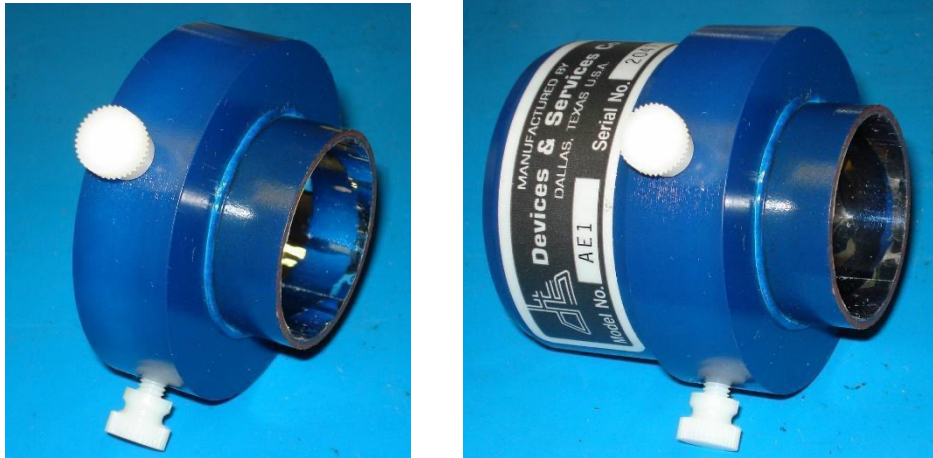

Standard AE-ADP adapter with highly reflective film that redirects radiation heat exchange

For measuring materials with low thermal conductivity, the port adapter has the advantage of reducing the heat load on the Sample. The combination of the reduced heat load and smaller port size makes it possible to use the “slide” method described in D&S Technical notes TN04-1 and TN10-2 with a smaller Sample area.

The port adapter can also be used for the measurement of cylindrical surfaces without a custom adapter to fit the geometry. The smaller port size reduces errors due to the non-flat surface geometry and due to detector alignment making it possible to manually position the detector. The remaining error due to the cylindrical shape can then be approximately corrected for a range of radiuses and surface emittance values.

A related issue is the measurement of rough or textured flat surfaces, having features significant in size relative to the detector to Sample spacing. The presence of surface features causes the Sample to be displaced from the port on average. It has been found that the port adapter reduces the error due to Sample displacement for high emittance materials. TN 08-1 “Model SSR-ER – Solar Reflectance Measurements of Irregular Surfaces” describes a similar approach to the correction of reflectance measurements.

The use of a port adapter necessarily changes the emittance measurement due to the redirection of reflected energy by the cylindrical section of the adapter, and the reduced port size. Due to the reflections from the adapter, the integration of emittance over angle is modified so that if the emittance standard and the unknown Sample have differing angular properties there can be an error introduced. A second source of error can result from reducing the port size. For the AE1 hemispherical emittance measurement the port can be thought of as diffusely illuminated with the reflected energy being collected from the entire area. Because some of the source energy may penetrate the surface by some distance before being reflected back out, there can be some reflected energy that escapes at the edge of the port. The leakage at the edge results in a lower apparent reflectance and thus a higher emittance value. For a smaller port the loss of reflected energy is a larger percentage of the total and therefore an error can occur unless the properties of the standard and the Sample are the same. These potential errors are not investigated in detail here; however measurements for different surfaces with and without the port adapter are compared to indicate that significant differences are unlikely for common materials.

Measurement of Materials with Low Thermal Conductivity

The procedure for making measurements with the adapter on materials with low thermal conductivity is detailed below. The basic steps are the same as those for making standard measurements without the adapter. The instrument is first calibrated with high and low emittance standards to establish a straight line relationship between the detector output and the emittance values of the standards. With the port adapter in place it is necessary to adjust the offset using the offset adjustment on the voltmeter (if using the D&S model RD1). Once calibrated the high emittance standard is used to track calibration drift due to small changes in detector temperature and room temperature. The additional step for materials with low thermal conductivity is to move or “slide” the detector sequentially to unheated areas of the Sample over a period of about one minute so that the detector transient response plays out over an area of the Sample that is near the correct surface temperature. If the material cannot be applied to the heat sink, a preliminary step is needed to assure that the Sample and the standards are at the same temperature.

The table below compares emittance values measured with and without the port adapter for various materials including some with low thermal conductivity. These measurements and others reported in this note were made with an RD1 Scaling Digital Voltmeter with the gain increased by 10 times. The reporting of emittance to three decimal places is for comparison purposes and is not indicative of the accuracy or repeatability of the instrument for any particular measurement. The emittance values reported are the average of two or more readings.

<u>Sample</u>	<u>Emittance w/adapter</u>	<u>Emittance w/o adapter</u>
Acrylic coating over Ni plating	0.705	0.704
Acrylic coating over Ni plating	0.458	0.451
Electroless Ni plating	0.142	0.138
Yellow vinyl tape	0.912	0.908
Gray duct tape	0.808	0.792
5/8” Gray plastic	0.902*	0.905*
White ABS	0.916*	0.916*
Press board	0.906*	0.902*

* slide method used to make measurement

These results suggest that for typical materials, using the port adapter is unlikely to result in readings significantly different than making a standard measurement with the model AE1 Emissometer.

Procedure for measuring materials with low thermal conductivity

1. Install the port adapter on the AE1 Emissometer and power it up. Allow about 15 minutes for the detector/adapter combination to warm up to a steady operating temperature. *Note that measurements with the adapter must be made with the detector oriented vertically to prevent errors due to convection.*
2. Calibrate with the high and low emittance standards applied to heat sink with a few drops of water. Adjust the voltmeter gain to set the high emittance value. Important Note – Adjust the *voltmeter offset* (not the detector head offset) to set the low emittance value. There is not enough offset range available on the AE1 detector head to make the adjustment. Some iteration is required.



3. Remove the low emittance standard from the heat sink. For each measurement it may be necessary to make fine gain adjustments on the high emittance standard. The low emittance standard need only be checked occasionally. For high emittance Samples, small errors in detector offset are not important.

4. NOTE: If the Sample is not flat, too large, or cannot be applied to the heat sink with water see the instructions below. For small flat Samples apply the Sample to the heat sink with sufficient water to get good thermal contact. Allow a few minutes for the Sample to come to thermal equilibrium.



5. Hold the detector/adapter flat against the Sample on one corner for about 20 seconds and then “slide” it to an adjacent corner. Move to each subsequent corner after about 15 seconds. Avoid a major break in contact with the surface which will cause an unwanted transient in the detector response. The reading may increase a small amount upon each move due to the lower surface temperature at the new location. The maximum reading obtained on corner number four is the value for this single measurement. To get an average of several readings, start and end at different locations on the Sample. Allow a few minutes for the Sample to return to an equilibrium temperature and readjust the gain on the high emittance standard between each measurement.

Procedure for measuring materials that cannot be applied to the heat sink

Calibrate the AE1 Emissometer as described above in steps 1 through 3. Continue with step 4 below.

4. For a material that cannot be applied to the heat sink, set the detector aside after calibration and use a small fan to bring the Sample and the heat sink, with the high emittance standard applied, to the same temperature. Turn off the fan and then place the detector with adapter on the high emittance standard.

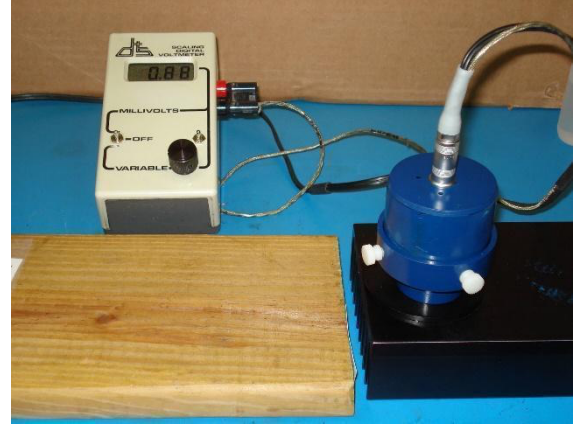

5. Leave the detector on the high emittance standard for two to three minutes until the reading is completely stable and adjust the gain so that the display reads the emittance of the standard.

6. Hold the detector/adapter flat against the Sample on one corner for about 20 seconds and then “slide” it to another spot. Move to each subsequent different location after about 15 seconds or more frequently if the Sample size is sufficient. Avoid a major break in contact with the surface which will cause an unwanted transient in the detector response. The reading may increase a small amount upon each move due to the lower surface temperature at the new location. The maximum reading obtained at the last location (after about one minute) is the value for this single measurement. To get an average of several readings, start and end at different locations on the Sample. Return to step four, cool the Sample and heat sink for a few minutes and readjust the gain on the high emittance standard between each measurement.



Measurement of Cylindrical Surfaces

For non-flat surface geometries the measurement is affected by several factors. Since the Sample does not fit flat against the port it is necessarily improperly illuminated by source radiation from the heated detector surface. This is similar in effect to the “leakage” at the port edges discussed in the introduction and to the improper illumination of rough or textured surfaces described in a following section. In addition, the differential sensing element must be positioned repeatable relative to the surface to avoid offset errors and errors due to sensor elements viewing the surface asymmetrically. Since the surface does not seal against the port there is also the possibility that air flow will alter the detector reading. In addition, a cylindrical surface typically cannot be applied to the heat sink for measurement and may also be a poor thermal conductor. The “slide” technique may be required to compensate for surface heating.

To control measurement errors a custom adapter is typically created for non-flat surface geometries. The adapter seals against the surface ensuring repeatable alignment and preventing air flow over the detector surface. A custom set of high and low emittance standards is made to match the surface geometry. To determine the emittance values of the standards, film materials such as aluminum and vinyl tape are measured flat and then applied to the non-flat surface. The taped surfaces are used as intermediaries to measure the emittance of the working standards.

For a surface with a large enough radius of curvature and high emittance it is possible to make direct measurements using the port adapter, without requiring a custom adapter and custom emittance standards. Positioning errors are small enough so that an operator can manually align the detector. With the port adapter, corrections for the surface geometry are small for a range of cylindrical radiuses and emittance values. To prevent air flow over the detector surface, a flexible bellows is used to seal against the cylindrical surface.

To establish correction factors for cylindrical surfaces, a number of different model AE1 Emissometers were tested with the model AE-ADP port adapter on four radiuses ranging from 2 to 6 inches. The measurements were made as described below, calibrating the detector/adapter combination on the usual flat emittance standards. Standards matching the cylindrical shape are not required because the correction is small as shown. Two different vinyl tapes were measured applied to anodized aluminum pieces that were machined to the indicated radiuses. The aluminum pieces were attached to a heat sink alongside the emittance standards so that the temperatures were all close to the same.

Gray duct tape:

AE1 #	Flat	2"	3.33"	4.66"	6"
AE1 #1	0.803	0.826	0.817	0.813	0.812
AE1 #2	0.801	0.824	0.816	0.810	0.810
AE1 #3	0.804	0.823	0.818	0.811	0.810
AE1 #4	0.805	0.820	0.814	0.811	0.810

AE1 #5

Flat	2"	3.33"	4.66"	6"
0.802	0.819	0.816	0.812	0.812

AE1 #6

Flat	2"	3.33"	4.66"	6"
0.805	0.825	0.818	0.812	0.811

Yellow vinyl tape

AE1 #1

Flat	2"	3.33"	4.66"	6"
0.913	0.926	0.921	0.916	0.912

AE1 #4

Flat	2"	3.33"	4.66"	6"
0.912	0.919	0.919	0.913	0.912

Note that the difference between the reading on the flat surface and the curved surface is smaller for the higher emittance surface. This would be expected because the loss of reflected energy due the displaced surface is smaller for the high emittance surface since it has a lower reflectance.

Using the average of the measurements of the two vinyl tapes, a correction for measurements using the port adapter was determined. For cylindrical surfaces with a radius of curvature of two inches or greater and an emittance of 0.80 or greater, the following

relationship approximately corrects the indicated emittance to the surface emittance of the Sample.

e = surface emittance,

e_i = indicated emittance,

r = radius of curvature in inches,

$$e = e_i - 0.167 * (1 - e_i^2) / r^{1.32}$$

Note that the corrected emittance value of the cylindrical surface is the surface property of the material as if it were flat. An extended surface with a cylindrical Profiled such as a typical roofing Tile will always have an effective emittance slightly higher than the surface emittance of the material because there is more actual surface area than projected surface area.

Procedure for cylindrical surface with emittance > 0.80, radius of curvature > 2 inches

To minimize errors due to detector alignment, attach the adapter symmetrically as shown in the photo. The position of the screws will be used to align the detector with the axis of the cylindrical surface which minimizes errors due to slight misalignment.

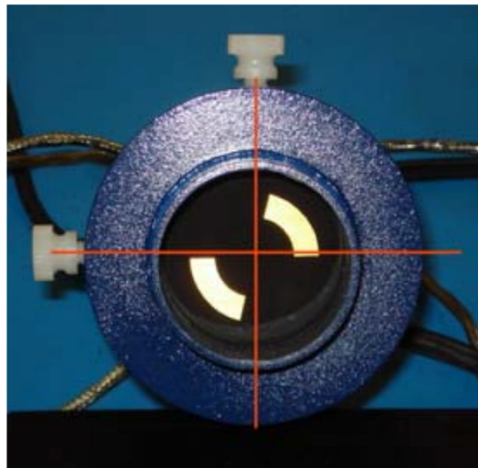

Calibrate the AE1 Emissometer as described in steps 1 through 3 above and continue with step 4.

4. A cylindrical surface cannot be applied effectively to the heat sink, therefore set the detector aside after calibration and use a small fan to bring the Sample and the heat sink, with the high emittance standard applied, to the same temperature. Turn off the fan and then place the detector/adapter on the high emittance standard.



5. Leave the detector on the high emittance standard for two to three minutes until the reading is completely stable and adjust the gain so that the display reads the emittance of the standard.



6. Place the bellows on the Sample and hold the detector/adaptor vertical, square and centered on the cylindrical surface, inside the bellows. Align one of the nylon screws with the axis of the cylindrical surface to ensure that the detector elements view the Sample symmetrically. Use the slide technique if the Sample size is sufficient. For the Sample shown there is only room for two spots with the detector held vertically. It is preferable to have a larger Sample. To get an average of several readings, start and end at different locations on the Sample. Return to step four, cool the Sample and heat sink for a few minutes and readjust the gain on the high emittance standard between each measurement. There is a small correction (maximum of about 0.02) that is required to account for the surface geometry.

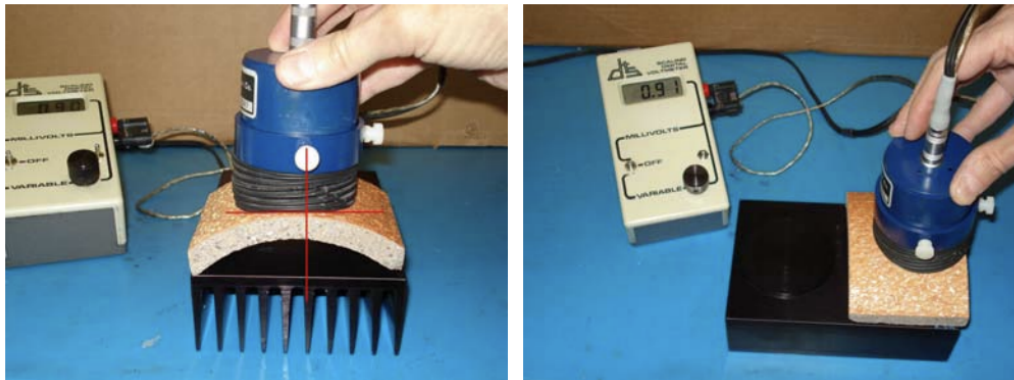



Correction factor for a cylindrical surface:

e = surface emittance,

e_i = indicated emittance,

r = radius of curvature in inches,

$$e = e_i - 0.167 * (1 - e_i^2) / r^{1.32}$$

APPENDIX 2: MONO-COLOR CALCULATION METHOD FOR VARIEGATED SHINGLES, STONE-COATED METAL, AND GRANULE-SURFACED ROLL PRODUCTS

Each separate granule product used in a Variegated shingle or granule-surfaced roll product must have initial and aged CRRC ratings. Rapid Ratings values may be utilized until the product completes the required three-year weathering process and aged testing. Each product must be prepared and evaluated individually on “mono-color” Specimens. The initial and aged Solar Reflectance and Thermal Emittance values of the Variegated product shall be determined using the calculation shown below. The initial Solar Reflectance and Thermal Emittance of the Variegated product shall also be measured using CRRC-1 Test Method #1 and the Slide Method, respectively. These measurements may be taken by either a CRRC Accredited Independent Testing Laboratory or the Licensee. The calculated initial Solar Reflectance and Thermal Emittance must be within ± 0.05 of the tested values.

The calculated initial and aged Solar Reflectance and Thermal Emittance values shall be determined using the formula below, which incorporates the reflectance/emittance and percent coverage of each granule color included in the Variegated shingle or Variegated Stone-Coated Metal product. For initial results, both the calculated and tested values shall be submitted to the CRRC via the Online Rating Portal.

$$\left(\sum_{i=1}^n r_i \times u_i \right) = R$$

r_i = Solar Reflectance of granule color i

u_i = Percentage usage of granule color i

n = Number of granule colors

R = Solar Reflectance of Variegated product

Note: Mass fraction shall be used for u_i

The example below illustrates how the overall reflectance is calculated for a Variegated shingle, Stone-Coated Metal product, or granule-surfaced roll product containing 80% black granules (mono-color Specimen with a reflectance of 0.01), and 20% white granules (mono-color Specimen with a reflectance of 0.50).

Example:

$$\begin{aligned} & \left(\frac{\text{Black Granule}}{\text{Reflectance}} \right) \times \left(\frac{\text{Black Granule}}{\text{Percent Usage}} \right) + \left(\frac{\text{White Granule}}{\text{Reflectance}} \right) \times \left(\frac{\text{White Granule}}{\text{Percent Usage}} \right) \\ & 0.01 \quad \times \quad 80/100 \quad + \quad 0.50 \quad \times \quad 20/100 \\ & \quad \quad \quad = \text{(Overall Reflectance)} \\ & \quad \quad \quad 0.11 \end{aligned}$$

APPENDIX 3: VALIDATION TESTING PROCEDURES

Last updated October 2, 2024

Background

The CRRC Board of Directors approved the Validation Testing (VT) Program on June 6, 2024. The Validation Testing Program replaced the previous CRRC Random Testing Program, effective January 1, 2025.

Purpose

Section 3.6 of the CRRC-1 Roof Product Rating Program Manual calls for validation testing of actively rated products in order to verify the values and retain the credibility of the CRRC Rated Roof Products Directory. This document describes the policy and procedures of the CRRC Validation Testing Program.

Validation Testing Policy

This section describes the requirements for Licensees with active product ratings on the CRRC Rated Roof Products Directory whose products are due for Validation Testing.

1. The Validation Testing Program is conducted on a calendar-year schedule and is expected to be completed by the end of the calendar year.
2. At the start of each Validation Testing Program cycle, the Licensee must submit their decision through the CRRC Online Rating Portal (Portal) for each product due for Validation Testing to determine if a product will proceed with testing, voluntarily terminate, or proceed with a Formula Change or Retesting application to replace the existing product.
3. For products proceeding with Validation Testing, the CRRC will designate the AITL that will receive the test specimens (Specimens) for Validation Testing. The Licensee is required to ship the Specimens to the AITL within 10 to 15 business days of CRRC assignment.
4. It is the responsibility of the Licensee to initiate Validation Testing at the beginning of each year, providing adequate time for the AITL to submit Validation Testing test results to the CRRC prior to the end of the year, including second tests, if required. Failure to have passing Validation Testing results will result in the product's permanent removal from the CRRC Rated Roof Products Directory at the end of the year (December 31).

Validation Testing Procedures

Selection of Rated Roofing Products for Validation Testing

Products with active CRRC ratings will be due every seven (7) years for Validation Testing with the exception of Reference and Blend Assembly products. Reference and Blend Assembly products are excluded from Validation Testing because they are indirectly subjected to Validation Testing through the parent product. The CRRC will terminate any product listed on the CRRC Rated Roof Products Directory that has not completed and passed Validation Testing every seven (7) years.

Products shall undergo Validation Testing by a CRRC-designated AITL.

Products may also be manually selected for Validation Testing through Challenge Testing to address a specific need, or in response to a concern or formal complaint as outlined in Chapter 6 of the CRRC-1 Roof Product Rating Program Manual.

The Licensee has the option to re-rate a product that is due for Validation Testing without going through the Validation Testing process. If the Licensee chooses to re-rate the product without going through Validation Testing, the Reformulated or Retested Product Rating Procedure shall be followed in accordance with section 3.9 and Appendix 6 of this manual. The existing rating may be retained until the new rating is published or until the December 31 of the Validation Testing year, whichever is sooner.

Laboratory Selection and Testing Process

1. Each year, the CRRC will send all AITLs an invitation to participate in the Validation Testing Program; AITLs may opt out of participating.
2. For AITLs that confirm their participation, they:
 - a. Agree to test products for the Validation Testing Program for a predefined, negotiated price per product that may vary by product type, and
 - b. Will be assigned products by the CRRC based on laboratory availability on a rotating basis. To increase efficiency and prevent delays, the CRRC will refrain from assigning new products to the same AITL if the AITL has not submitted Validation Testing results for previously assigned products.
3. The CRRC will inform the AITL when a product has been assigned to be shipped to them.
 - a. The AITL should expect to receive the Validation Testing product from the Licensee within approximately 15 days of being notified.
 - b. If the AITL has not received the Validation Testing product within approximately 15 days of being notified, they should contact the CRRC.
4. The AITL shall inspect the Validation Testing package upon receipt to ensure that the Validation Testing samples were not damaged during shipping, Validation Testing samples are properly labeled, and confirm that a copy of the Sample Tag and brief preparation instructions are enclosed.
 - a. If the Validation Testing samples have been damaged during shipping, incorrectly or not labeled, or the package does not contain a copy of the Sample Tag or brief preparation instructions, the AITL shall notify the CRRC immediately.
5. The AITL is required to photograph Specimens of all products undergoing Validation Testing. The photographs shall be uploaded to the CRRC Online Rating Portal, along with the test results (see Appendix 4).
6. CRRC-designated AITLs must conduct testing of the Validation Testing specimens **according to the most current CRRC approved test methods** and report the test results via the CRRC Online Rating Portal within four (4) weeks of receipt of the Specimens.
7. The AITL will directly invoice the CRRC at the predetermined negotiated amount per product.
8. The CRRC will review the Validation Test Results prior to paying the AITL invoice.
9. The AITL is required to hold the Specimens for at least one month (30 calendar days) following completion of testing.

If a product fails to meet the Validation Testing Program requirements in the first Validation Test, the CRRC will assign a second AITL to perform a second test following steps 2 through 9.

Shipping Samples of Rated Products for Validation Testing

When a rated product participates in Validation Testing, the CRRC will inform the Licensee which AITL they will need to ship the Validation Testing Specimens to. The Licensee must ship the Validation Testing specimens directly to the CRRC-designated AITL within 15calendar days of the AITL designation.

1. When preparing the Validation Testing package before shipping it to the AITL, the Licensee shall:
 - a. Label the untested side (back) of each Validation Testing Specimen with the CRRC Product ID
 - b. Package Validation Testing Specimens appropriately to ensure that the Specimens are not damaged during shipping
 - c. Include a copy of the Sample Tag from the CRRC Online Rating Portal in the package; **and**
 - d. Include a copy of a Safety Data Sheet and a Technical Data Sheet containing application instructions in the package, where applicable

Licensees are responsible for shipping the Sample directly to the CRRC-designated AITL. Samples can be provided by a routine production batch, a one-time/single-run batch, a retain sample, a separate party (e.g., fabricator or private label producer), or a lab batch, as long as traceability is provided.

The Sample size that Licensees ship to AITLs for Validation Testing will vary by product type. Standard product specimens shall be a minimum of 10.2 centimeters by 15.2 centimeters (4 inches by 6 inches) in size following the

requirements outlined in Section R.S.3 of ANSI/CRRC S100. For all product types except Variegated, Wood and Multi-Shade Polymer/Composite, and Tile products, one (1) Specimen from *one (1)* lot/batch must be shipped, but two (2) Specimens from *one (1)* lot/batch is recommended.

Asphalt and Stone Coated Metal Shingle products shall have a minimum dimension of 25.4 centimeters by 91.4 centimeters (10 inches by 36 inches) of exposure surface. Asphalt and Metal Shingle Specimens shall include at least two (2) full courses of exposure surface in height following the requirements outlined in Section R.S.3.4 of ANSI/CRRC S100.

Variegated products that are not Asphalt or Stone Coated Metal Shingle products, shall have an area of at least 10.2 by 25.4 centimeters (4 inches by 10 inches) and shall include at least two (2) Specimens from *one (1)* lot/batch that properly represents the variation of the product following the requirements outlined in Section R.S.3.4 of ANSI/CRRC S100.

Wood and Multi-Shade Polymer/Composite products, shall be shipped in arrays of three (3) panels to capture the widest range of color variation. Each array shall contain one light-colored panel, one medium-colored panel, and one dark-colored panel following the requirements outlined in Sections R.S.2.2(F) and (G) of ANSI/CRRC S100.

Tile products both mono-color and variegated, shall undergo the following process following the requirements outlined in Section R.S.3.2 of ANSI/CRRC S100:

- Tiles shall be flat, unless only Profiled products are available.
- The Licensee will cut nine (9) Samples to approximately 15 centimeters by 15 centimeters (6 inches by 6 inches) from nine (9) Tiles, unless cut tiles cannot be provided.

Validation Testing of Certain Products

Validation Testing for Liquid-Applied Roof Coatings and Single-Ply Membranes

When the AITL receives a container of liquid coating, the AITL will apply the coating to a bare aluminum panel (10.2 centimeters by 15.2 centimeters or 4 inches by 6 inches in size) following the Manufacturer's application instructions. The AITL may also receive an aluminum panel with the Liquid-Applied Roof Coating already applied. In either case, the AITL must conduct a Coating Thickness test in accordance with Chapter 2.0 of the CRRC-1 Roof Product Rating Program Manual. The average Thickness of the measured coating for each Specimen must be within 20% of the Manufacturer's recommended minimum Thickness. Thickness testing must also be completed for Single-Ply Membrane products in accordance with Section 2.2.8 of the CRRC-1 Roof Product Rating Program Manual (Single-Ply Thickness Tests).

Validation Testing for Rough Substrates

Actively rated coating products applied to a Rough Substrate are eligible for Validation Testing selection and are subject to the requirements outlined in the CRRC-1 Roof Product Rating Program Manual. Products due for Validation Testing must undergo the Specimen preparation and initial testing procedure as described in Appendix C of ANSI/CRRC S100. A completed copy of the Coatings on Rough Substrates Excel Reporting Tool must be provided to the CRRC along with the test results.

Validation Testing for Color Family Product Ratings

The Validation Testing Program will verify that the Hunter L, a, b color coordinates are correct and that the product has been placed in the appropriate Color Family. The Radiative Properties of the product measured through Validation Testing must meet the requirements set forth in the "Evaluating Validation Testing Results" section below.

Validation Testing for Color Family Representative Elements

If a Color Family Representative Element fails Validation Testing, the entire Color Family, including Additional Elements, are considered out of compliance with the requirements in the CRRC Roof Product Rating Program. To keep the Color Family active, the Licensee must:

1. Submit a Formula Change or Retesting application for the Representative Element and the Additional Elements will be moved to reference the new Representative Element. Once the reformulated application has approved Initial Test Results, the failed Representative Element will be Replaced or will Terminate at the end of the year (December 31), whichever is sooner, or
2. The Licensee may convert an Additional Element to become the Representative for that Color Family by submitting a new Representative Element application and proceeding with the Initial and Aged Testing Requirements located in Section 3.5 of the CRRC-1 Roof Product Rating Program Manual. The other Additional Elements will be moved to reference the new Representative Element and the failed Representative Element will Terminate at the end of the year (December 31).

If the Licensee does not proceed with either of the above options, then all of the product ratings included in the Color Family shall be Terminated and removed from the Rated Products Directory at the end of the year (December 31).

Validation Testing for Color Family Additional Elements

If a Color Family Additional Element fails Validation Testing, it is removed from the CRRC Rated Roof Products Directory without influencing the rest of the Color Family Group. The Additional Element will Terminate at the end of the year (December 31).

Evaluating Validation Testing Results

The objective of Validation Testing is for the CRRC to evaluate the product that was originally submitted for CRRC Rating. In the case of Compound Ratings, where multiple products are listed under one CRRC Product ID, the manufacturer should submit the same specimen profile that was originally tested. If the original profile is not available, the submitted specimen will still be evaluated under the below criteria. The results of Validation Testing will be compared to the data reported in the Portal. The product is deemed to have **passed** the Validation Test if:

- The Solar Reflectance test results are no more than ± 0.05 from the listed initial product rating, **and**
- The Thermal Emittance test results
 - are no more than ± 0.05 for products with an initial emittance of 0.30 or less from the listed initial product rating, **or**
 - no more than ± 0.10 for products with an initial emittance greater than 0.30 from the listed initial product rating.

For example, if the listed initial Solar Reflectance is 0.50, then any test result that is between 0.45 and 0.55 (inclusive) is considered passing.

If the Validation Test results meet the threshold above, the product is considered to have passed Validation Testing for the year and the product's rating will remain active for an additional seven (7) years. If the results from the Validation Test differ from the listed initial product ratings beyond the threshold described above, the CRRC will follow the procedure below for retesting the Samples.

Retesting of Validation Testing Samples

When a product fails to meet the requirements of Validation Testing with passing results, the CRRC will first contact the AITL that performed the Validation Testing to confirm there are no typographical or other errors in the reported results.

If there are no errors, the CRRC will notify the Licensee and request that new samples from a different batch or production source from the first Validation Testing be shipped to a second CRRC-designated AITL for validation testing following the Validation Testing Procedures outlined in this appendix.

If the product meets the requirements of Validation Testing in the second test, then the product is considered to have passed Validation Testing, and the product's rating remains active for an additional seven (7) years.

If the results from the second test do not meet the requirements set forth in the “Evaluating Validation Testing Results” section above, the product is considered out of compliance with the requirements of the CRRC Roof Product Rating Program, and the product shall be Terminated and removed from the Rated Roof Products Directory at the end of the year (December 31). Terminated products are not eligible for reactivation.

The Licensee shall cease and discontinue the use of the CRRC Rated Product Logo or CRRC Product Label from any product packaging, marketing materials (digital or print), product specification sheets, and anywhere else that the logo and label are being used upon termination on December 31.

If a product that is being Privately-Labeled is Terminated due to a Validation Testing failure, all corresponding product ratings (i.e. Reference ratings) that rely on the original Manufacturer’s rating will also be Terminated.

If any of the products listed under a Compound Rating fails Validation Testing, including the representative, the complete product listing shall be Terminated.

APPENDIX 4: PRODUCT RATING PROCEDURE DETAILS: INITIAL AND AGED TESTING

Last updated September 24, 2020

Purpose

To participate in the CRRC Roof Product Rating Program, an interested Manufacturer or seller must be a current Licensee with a Licensee identification number assigned by the CRRC. For more information on obtaining a license, visit <http://coolroofs.org/product-rating/become-a-Licensee>.

The complete product rating procedure (including obtaining both initial and aged ratings) consists of the steps outlined below. All forms are available for download from the Roof Product Rating Program tab on the CRRC website.

Initial Product Rating Procedure

1. The Licensee submits a product rating application to the Online Rating Portal indicating they are seeking a CRRC rating. The Licensee shall fill out the brand name and model name and/or number on the product rating application (CRRC Online Rating Portal) so that the brand and model specify only the product for which the rating applies.
2. The Licensee sends the Roofing Product Sample and Test Farm Notification Form [Exposure Placement] (CRRC-F-7) to an Accredited Independent Testing Laboratory (AITL) of choice for measurement of Initial Radiative Properties in accordance with the CRRC-1 Roof Product Rating Program Manual (see below requirements for products tested in accordance with ASTM E1918 – ‘Standard Test Method for Measuring Solar Reflectance of Horizontal and Low-Sloped Surfaces in the Field’). The AITL establishes billing arrangements with the Licensee.
3. Each test Specimen shall be labeled such that it can be uniquely identified by Batch and Sample within each Batch. Labels shall be designed to be durable for at least a four-year period, during which the Samples will be exposed to the environment.
4. Starting on and after July 1, 2018, the AITL shall take a photograph of each Sample (set of test Specimens) during the initial testing process.
 - The Licensee should label the back of each Specimen prior to shipping the product Sample to the AITL. The labels are used for identification purposes.
 - The AITL shall submit all photos for a particular product undergoing initial testing to the CRRC by uploading them to the Online Rating Portal.
 - The AITL must include the following information in the file name of each digital photo:
 - Initial testing (versus Aged testing)
 - Rapid Rating product (i.e., lab-aged product), if applicable
 - Date photo was taken
 - Specimen numbers
 - If the label is on back of the Specimen, a photo of the front and back of the Specimen must be taken.
 - If the label is placed next to the front of the Specimen, only the front of the Specimen can be photographed.
 - Multiple Specimens can be grouped together in a single photograph (front and back, depending on label placement) as long as the entire surface of each Specimen is clearly visible in the photograph.
 - Proper lighting and image quality (i.e., high resolution) are required.
 - Required file nomenclature template for AITL initial testing photos:
 - For standard rated products:

- Initial_NE-YYYY-MM-DD_[Specimen]#
- For Rapid Ratings products:
 - Initial_RR-YYYY-MM-DD_[Specimen]# (before soiling)
 - Soiled_RR-YYYY-MM-DD_[Specimen]# (after soiling)

Photo File Nomenclature Key	
Initial	Initial Testing
NE	Natural Exposure (versus Rapid Rating)
RR	Rapid Rating
Specimen #	Identification number on back of panel, as provided by Licensee

5. The AITL measures the Initial Radiative Properties of the test Specimens and reports the initial test results via the CRRC Online Rating Portal.
 - For each Standard Roofing Product and Color Family Representative Element being tested (see section 3.5 for Color Family Additional Elements), a total of nine (9) Specimens shall be selected from two Batches, distributed as follows into the following groups:
 - A. Three Specimens from one Batch
 - B. Three Specimens from second Batch
 - C. Three Specimens, for which both Batches must be represented
 - D. Specimen size is dependent on product type but shall not be smaller than 155 square centimeters (24 square inches), with the minimum dimension on any side being no less than 7.62 centimeters (3 inches).
 - For Variegated shingles or Stone-Coated Metal products with non-continuous (particle) top coatings that are tested in accordance with CRRC-1 Test Method #1 (see CRRC-1 Roof Product Rating Program Manual, section 3.5.5), a total of three (3) Specimens shall be selected from two Batches (Samples may be comprised of multiple pieces). The Specimens shall be prepared and grouped as follows:
 - A. One Specimen comprised of product (at least two shingles or Stone-Coated Metal shingles from one Batch;
 - B. One Specimen comprised of product (at least two shingles or Stone-Coated Metal shingles from a second Batch; and
 - C. One Specimen comprised of approximately equal proportions from both Batches (at least one shingle or Stone-Coated Metal shingle from each).
 - D. The set of all Specimens to be tested in accordance with CRRC-1 Test Method #1 shall have at least 25.4 centimeters by 91.4 centimeters (10 inches by 36 inches) of exposure surface. Composition shingles or Stone Coated Metal shingles Samples shall include at least two courses (two full courses of exposure surface in height).

Advisory Note: at least two shingles or Stone-Coated Metal shingles are required for each Specimen for a total of at least six shingles. Licensees may elect to send more than two shingles per Specimen if desired to reduce the risk of Uncharacteristic Damage.

- For Variegated products that are not shingles or Stone-Coated Metal shingles that are tested in accordance with CRRC-1 Test Method #1, Specimens shall be randomly selected from routine production and sent to an AITL for testing. These Specimens shall be grouped into three sets:

- A. Three Specimens from one Batch;
- B. Three Specimens from a second Batch;
- C. Three Specimens for which each of the two Batches shall be represented.
- D. Each Specimen to be tested in accordance with CRRC-1 Test Method #1 shall have at least 10.2 centimeters in length or 25.4 centimeters in width (4 inches by 10 inches) of exposure surface.

- For products submitted under a Compound Rating:
 - A. Single-Ply products - the thinnest product must be tested.
 - B. Shingle, Stone-Coated Metal shingle products, or modified bitumen products - the representative product must be submitted for testing.
 - C. Polymer shake, slate or Tiles - all shapes must be measured to determine the lowest reflectance. The shapes with the lowest reflectance will be used as the CRRC initial and aged product rating values. The Profiled product with the lowest reflectance will be sent to the test farm for weathering.
- For products that are tested in accordance with ASTM E1918, product Samples shall be randomly selected from routine production and sent to an AITL or Approved Test Farm for initial testing. Per CRRC policy, initial testing must be completed by an AITL. Initial measurements shall be made on only one test Specimen. Only three (3) Specimens per product Sample are required for three-year exposure.
- For aggregate Roofing Products, see Appendix 7.

6. The AITL sends all test Specimens with the Test Farm Notification Form [Exposure Placement] (CRRC-F-7) (submitted by the Licensee) to the designated test farm’s central weathering site, the address of which is listed on the CRRC web page (see below exception for products tested in accordance with ASTM E1918). Specimens must be sent to the test farm by the AITL no later than twenty-eight (28) calendar days prior to the next test farm placement date to ensure that Sample(s) reach the test farm in time for that placement. The test farm will distribute the Specimens for exposure at all three sites¹ in time for panel placement for coordinated exposure initiation. Exposures will begin on the first day of every other month throughout the year, beginning with January 1. The test farm shall take a photo of the Specimens once they have been placed for exposure. Specimens received by the test farm within twenty-one (21) calendar days of each bi-monthly placement date will be held and exposed at the next placement date.

Specimens shall be distributed among the three Test Farm Sites such that both Batches are represented at each Test Farm Site, with the following exceptions:

- A. For products tested in accordance with ASTM E1918, only three Specimens per product Sample are required for three-year exposure. One test Specimen per Sample will be placed at each Test Farm Site for three-year exposure. Specimens must be sent to each Test Farm Site (not the test farm’s central facility) no later than twenty-eight (28) calendar days prior to the next test farm placement date to ensure that Specimen(s) reach the test farm in time for that placement. Exposures will begin on the first day of every other month throughout the year, beginning with January 1. Specimens received by the test farm within twenty-one (21) calendar days of each bi-monthly placement date will be held and exposed at the next placement date.

See section 3.5.7 of the CRRC-1 Roof Product Rating Program Manual for more information about products tested in accordance with ASTM E1918.

¹ Weathering sites shall be located in the climates listed in the section titled “Test Farm Sites” at the end of this appendix.

- B. For Wood and Multi-Shade Polymer/Composite products that are tested in accordance with Section R.S.2.2(F or G) of ANSI/CRRC S100, one array of light, medium, and dark panels shall be distributed to each Test Farm Site.

See below for details on the weathering process.

7. The test farm labels test Specimens (if necessary), establishes billing arrangements with each Licensee,² and initiates exposure testing in the outdoor environment upon receipt of Specimens in accordance with ASTM G7 – *Standard Practice for Atmospheric Environmental Exposure Testing of Nonmetallic Materials*. All Specimens are exposed with plywood backing material of the test farm’s choice. Products designated for only steep slope applications ($\geq 2:12$ slope) shall be exposed on plywood backing at 45°S. All other products shall be exposed on plywood backing at 5°S. After the Specimens are placed on the exposure racks, the test farm takes initial placement photos of the Specimens and enters the photos and exposure placement details into the CRRC Online Rating Portal. The test farm retains at least one copy of the Test Farm Notification Form [Exposure Placement] (CRRC-F-7) for use after the three-year exposure period.
8. The AITL reports the initial test results via the CRRC Online Rating Portal.
9. The CRRC lists initial product ratings on the CRRC Rated Roof Products Directory. A blank product label with initial product ratings is available to the Licensee upon request.

Aged Product Rating Procedure

1. Test Specimens undergoing weathering shall remain untouched for a period of three years.
2. Starting on and after July 1, 2018, test farm staff shall take a photograph of each set of Specimens at each Test Farm Site when placed for exposure and every year over the course of three-year weathering (i.e., at the time of placement and after 12, 24, and 36 months of exposure).
 - Multiple Specimens can be grouped together in a single photograph (front and back, depending on label placement) as long as the entire surface of each Specimen is clearly visible in the photograph. Proper lighting and image quality (i.e., high resolution) are required.
 - The photos shall be submitted to the CRRC per their instructions to the test farm.
 - The test farm staff must include the following information in the file name of each digital photo:
 - Test farm location (climate zone)
 - Date photo was taken
 - Specimen numbers
 - Required file nomenclature template for test farm photos:
 - FL/AZ/OH_Initial/12m/24m/36m..._YYYY-MM-DD_[Specimen]#

Photo File Nomenclature Key	
OH	Ohio Climate Zone
FL	Florida Climate Zone
AZ	Arizona Climate Zone
Specimen #	Specimen identification number
Initial/12m/24m/36m...	Initial placement, 12-month, 24-month and 36-month period during 36 months of natural exposure

² All exposure costs are incurred by the Licensee. Rates are negotiated between individual test farms and individual Licensees.

3. Near the end of the three-year weathering process, the test farm shall send a notification to the Licensee informing them of the pending removal of the weathered Specimens and to verify which AITL the Licensee selected for the aged testing measurements. At the end of the three-year exposure period, the test farm removes the Specimens from the exposure rack and labels each Specimen, consolidates them, and completes the reserved copy of the Test Farm Notification Form [Exposure Removal] (CRRC-F-7) with the exposure removal information (see below exception for products tested in accordance with ASTM E1918). The test farm then sends the Specimens, along with a completed version of the Test Farm Notification Form, to the AITL specified by the Licensee. The test farm also must enter exposure removal details into the CRRC Online Rating Portal within 30 calendar days of exposure removal. The test farm shall also provide CRRC with a cumulative list of CRRC exposed products after each placement/removal date.

Exception: For products tested in accordance with ASTM E1918, the test farm shall not remove the weathered Specimens until after the AITL has taken the aged measurements in situ at the test farm location. The test farm shall keep the weathered Specimens for a period of ninety (90) calendar days after the aged measurements have been taken, or until the Aged Radiative Properties are approved by the CRRC, before releasing the Specimens to the Licensee. Specimens will be covered to prevent additional exposure during the holding period. See section 3.5.7 of the CRRC-1 Roof Product Rating Program Manual for more information about products tested in accordance with ASTM E1918.

Note: The test surface of each Specimen shall not be washed, cleaned, or wiped in any fashion. Loose dirt, embedded dirt, environmental stains, mold, mildew and any other material that rests on—or has become incorporated into—the surface of the material shall not be altered.

4. Starting on and after July 1, 2018, the AITL shall take a photograph of each Sample (set of test Specimens) during aged testing.
 - The AITL shall submit all photos for a particular product undergoing aged testing to the CRRC by uploading them to the Online Rating Portal.
 - The AITL must include the following information in the file name of each digital photo:
 - Aged testing (versus Initial testing)
 - Test farm location (climate zone)
 - Date photo was taken
 - Specimen numbers
 - If the label is on back of the Specimen, a photo of the front and back of the Specimen must be taken.
 - If the label is placed next to the front of the Specimen, only the front of the Specimen can be photographed.
 - Multiple Specimens can be grouped together in a single photograph (front and back, depending on label placement) as long as the entire surface of each Specimen is clearly visible in the photograph.
 - Proper lighting and image quality (i.e., high resolution) are required.
 - Required file nomenclature template for AITL aged testing photos:
 - Aged/NE/OH/FL/AZ_YYYY-MM-DD_[Specimen]#

Photo File Nomenclature Key	
Aged	Aged Testing
OH	Ohio Climate Zone
FL	Florida Climate Zone
AZ	Arizona Climate Zone

Specimen #	Identification number on back of panel, as provided by Licensee
------------	---

5. The AITL conducts the aged testing and reports the aged test results via the CRRC Online Rating Portal. The AITL will send the Test Farm Notification Form [Exposure Removal] (CRRC-F-7) provided by the test farm to the Licensee. The AITL must submit test results via the Online Rating Portal within three (3) months (90 calendar days) of removal from the test farm. If aged data are not received within 90 calendar days, the product enters a 30-calendar day “under review” period and the Licensee will be notified. If the CRRC does not receive the aged data by the end of the “under review” period, the product will be suspended and removed from the CRRC Rated Roof Products Directory unless otherwise arranged with the CRRC.

The average Aged Radiative Properties shall be obtained by a straight average of the test results of each of measured Specimen. In the event that one or two Specimens are physically damaged or have some anomalous deterioration caused by factors beyond normal weathering during the three-year exposure period, the Specimen(s) shall be removed from the calculation of the averaged aged ratings. See section 3.5.1(D) of the CRRC-1 Roof Product Rating Program Manual for more information.

Note: Aged testing is a mandatory requirement for all Standard Roofing Products, excluding Color Family Additional Elements and Inactive Product Ratings.

6. The AITL shall be required to hold weathered Specimens for 90 calendar days or until the product’s aged data are listed with the CRRC (the AITL should contact the CRRC for this information). Any dispute over aged data between the Licensee and the AITL must be resolved between the two parties, using the test Specimens held by the AITL.
7. The CRRC lists the aged product ratings on the CRRC Rated Roof Products Directory. A blank product label with initial and aged product ratings is available to the Licensee upon request. Aged ratings for inactive products will be included on the Inactive Product Rating List (which will not be posted on the CRRC website but is available by request).

Test Farm Sites

Roofing product specimens shall be exposed in the following three (3) locations representing three (3) climate zones:

1. Hot/Humid climate with:
 - a. Annual Heating Degree-Day (HDD) @ 18 °C of 80 (Annual HDD @65 °F of 144), and
 - b. Annual Cooling Degree-Day (CDD) @ 10 °C of 5,334 (Annual CDD @ 50 °F of 9,602), and
 - c. An average yearly relative humidity of 82% in the A.M. and 61% in the P.M.
2. Cold/Temperate climate with:
 - a. Annual Heating Degree-Day (HDD) @ 18 °C of 2,978 (Annual HDD@ 65 °F of 5,361), and
 - b. Annual Cooling Degree-Day (CDD) @ 10 °C of 1,917 (Annual CDD @ 50 °F of 3,451), and
 - c. An average yearly relative humidity of 79% in the A.M. and 62% in the P.M.
3. Hot/Dry climate with:
 - a. Annual Heating Degree-Day (HDD) @ 18 °C of 486 (Annual HDD @ 65 °F of 874), and
 - b. Annual Cooling Degree-Day (CDD) @ 10 °C of 5182 (Annual CDD @ 50 °F of 9328), and
 - c. An average yearly relative humidity of 46% in the A.M. and 23% in the P.M.

The heating degree-day and cooling degree-day shall be determined in accordance with ANSI/ASHRAE Standard 169 as originally published in January 2021. The average yearly relative humidity shall be determined in accordance with NOAA comparative climate data. Test farm location climate values shall be within plus or minus 10% of those values shown above.

Advisory note: *Examples of regions of the United States that comply with these requirements are, but are not limited to, the following:*

Hot/Humid climate: Miami, Florida.

Cold/Temperate climate: Cleveland, Ohio; Pittsburgh, Pennsylvania.

Hot/Dry climate: Phoenix, AZ.

APPENDIX 5: COLOR FAMILY PROGRAM PROCEDURES

Last updated November 19, 2019

Purpose

Roofing materials may be supplied in a limited color palette or in an extensive number of colors. The CRRC provides a rating system that accommodates both situations. For those companies wishing to list individual products, these products may be submitted for testing as unique materials per the CRRC Product Rating Procedure Details in Appendix 4 of the CRRC-1 Roof Product Rating Program Manual. Some industries (e.g., factory-coated metal) have thousands of colors that may be supplied as roofing material. Rating each material would be onerous as well as prohibitively expensive. Since creating various colors within any roofing technology involves simply altering the selection and levels of pigments, it is reasonable to assume that the performance of a product, within a narrowly defined color range, will behave similarly to other products of similar—but not identical—color. For this reason, the CRRC has adopted the concept of Color Families,³ Color Family Groups, and processes to qualify a limited set of products, within a given Binder/Resin material technology, to represent the entire color line within that technology.

This document describes the processes whereby a Licensee may establish Color Family Groups, each with their own unique CRRC Product ID#, for one or more of their technologies under the CRRC Color Family Program and then subsequently include additional products (“Color Family Additional Elements”) in those Color Family Groups on the product application.

Qualifying Color Families within a Resin/Binder Technology

The CRRC has established seventeen (17) Color Families from which a Licensee may choose (see Table 1 below). Any of these seventeen Color Families may be selected by the Licensee, but for each selected Color Family and Binder/Resin Technology, the Licensee must rate a separate Color Family Group. For example, if a metal coil coating supplier has two principal products lines (e.g., polyvinylidene fluoride-based technology and silicone-modified polyester technology) with which they wish to participate in the CRRC Color Family Program, they will need to establish (rate) a Color Family Group for each Binder/Resin Technology for each of the Color Families that they choose. The CRRC has already defined the color limitations of each Color Family (see Table 1) and, by working carefully with industry partners, has also established “assigned values” for Solar Reflectance and Thermal Emittance. To participate in the Color Family Program, the submitter must be willing to accept these industry-wide assigned initial values.

Hunter “L,” “a,” and “b” color coordinates should be measured in accordance with ASTM E805, Section 9, with color measurement equipment specification: 0°/45° or 45°/0° (illuminant angle/viewing angle) geometry with 10° standard observer and D65 illuminant. Measurements shall be conducted on one product Specimen from both Batches A and B. The average measurement value for each coordinate (“L,” “a,” and “b”) shall be reported in the CRRC Online Rating Portal.

Qualification Process

1. The Licensee selects the Color Family in which they wish to establish a Color Family product. This must be done for each Binder/Resin material technology under consideration. A single product selected to represent the future Color Family Group (the Color Family Representative Element) is used to establish the Color Family Group.
2. In rating a Color Family Representative Element to establish its Color Family Group, the Licensee must follow all procedures outlined in the CRRC Product Rating Procedure Details in Appendix 4 of the CRRC-1 Roof Product Rating Program Manual.

³ Capitalized words are defined terms in the glossary of the CRRC-1 Roof Product Rating Program Manual.

Note: The Licensee is well advised to first ascertain—to the best of their ability—that their submission will meet or exceed the assigned Solar Reflectance and Thermal Emittance values for the Group as well as fall within the given Hunter “L,” “a,” and “b” ranges of the Color Family defined for the Color Family Group, as shown in Table 1 “Color Family Characteristics” below.

- a. The Licensee that is submitting the product Sample may determine the Hunter “L,” “a,” and “b” color coordinates of the Sample in accordance with section 3.5.2 of the CRRC-1 Roof Product Rating Program Manual prior to submitting to an AITL for Radiative Properties testing. These results will be given to the AITL to enter into the CRRC Online Rating Portal. The Licensee can also allow the AITL to measure and report the color coordinates.
 - b. The Initial Radiative Properties are reported to the CRRC by the AITL via the Online Rating Portal. The AITL then submits the Sample (set of Specimens) and the Test Farm Notification Form to the CRRC-Approved Test Farm for three-year aging in accordance with the CRRC Product Rating Procedure Details in Appendix 4 of the CRRC-1 Roof Product Rating Program Manual and ANSI/CRRC S100.
 - c. Once the Specimens have been placed out for exposure, the test farm inputs Specimen exposure information to the CRRC Online Rating Portal.
3. At this point, assuming all program requirements are met, the CRRC will list the Color Family Group on the CRRC Rated Roof Products Directory in the same fashion as standard products. The CRRC shall keep records to indicate that the rated Color Family Group allows for addition of future Color Family Additional Elements in this category (material type and color) for this Licensee.⁴
 4. Aged values are subsequently established for the Color Family Group through the aged Solar Reflectance and Thermal Emittance test results of the respective Color Family Representative Element. In all cases, upon aged testing, the aged values *or* initial assigned values are reported as the product’s aged values, whichever is lower.

Submitting a Color Family Element (i.e., Color Family Additional Element) into an Existing Color Family Group

Once a Color Family Group has been initially rated, the following procedure is used to populate the Color Family Group with additional, related but unique products called Color Family Additional Elements:

1. Prepare six (6) Specimens of the Color Family Additional Element, three from one Batch and three from a second Batch. Specimen size and substrate requirements are the same as for standard products. The Hunter “L,” “a,” and “b” color coordinates of the Specimens, measured in accordance with section 3.5.3 of the CRRC-1 Program Manual, must fall within the defined ranges of the appropriate Color Family Group, and the tested initial Solar Reflectance and Thermal Emittance must meet or exceed the assigned values of the Group.
2. Complete the product rating application(s) via the CRRC Online Rating Portal. A separate application is required for each Color Family Additional Element to be submitted into a Color Family Group.
3. Send test Specimens to an AITL. The AITL will measure the Radiative Properties – and if not to be measured by the Licensee, the Hunter “L,” “a,” and “b” color coordinates – and will report the results via the CRRC Online Rating Portal. No aged testing is necessary for Color Family Additional Elements.

Advisory Note: Photos are not required for Color Family Additional Elements, but if they are taken and submitted to the CRRC, the following file nomenclature should be used: CF_YYYY-MM-DD_(Specimen #)

⁴ For example, a “Red” Color Family Group established for 70% PVDF coating from Company X at this point in the program allows other similar shades of red 70% PVDF products from Company X to be rated as part of the “Red” Color Family Group thereby taking on the assigned Solar Reflectance and Thermal Emittance values associated with that Color Family Group, so long as the new color meets the “L,” “a,” and “b” Hunter color coordinate requirements for the “Red” Color Family in Table 1.

-
4. If all the test results comply with the CRRC Color Family requirements in Table 1 below, the new product will be listed under its Color Family Group on the CRRC Rated Roof Products Directory, inheriting the assigned values for initial Solar Reflectance and Thermal Emittance and the aged values established for the Color Family Group (described above).

Note: A Licensee who wishes to utilize reference ratings for Liquid-Applied Roof Coatings or factory-coated metal products that have already been rated by another Licensee with the CRRC as Color Family Elements may not establish their own Color Family Group(s) by relying on these ratings. To establish their own Color Family Group, the Licensee must rate the products themselves (as if there were no reference rating) according to the specifications as laid out in the above procedure. In order to utilize the Color Family Element ratings, the Licensee must submit the products as Standard Roofing Products and follow the product rating procedure as specified in Appendix 4 of the CRRC-1 Roof Product Rating Program Manual.

If the Licensee is relying on ratings for a Color Family Element, the rated values that the Licensee lists on the CRRC Rated Roof Products Directory and on the CRRC product label must be identical to the values listed for the referenced product.

If the measured “L,” “a,” or “b” color coordinate for a product seeking a Color Family Rating does not fall within a Color Family range, or the product fails to meet or exceed the Group’s assigned Solar Reflectance or Thermal Emittance values, the product shall be rated as a standard product.

Table 1: CRRC Color Families and Characteristics

Please Note: Initial measured values for Representative Elements and Additional Elements must meet or exceed the assigned SR and TE values shown below.

	Color Family	Hunter “L” range	Hunter “a” range	Hunter “b” range	Assigned SR	Assigned TE
1	Red	17 to 29	+7 to +36	0 to +15	0.25	0.83
2	Terra Cotta	20 to 38	+15 to +30	+6 to +16	0.35	0.83
3	Bright Red	23 to 38	+35 to +49	+10 to +48	0.35	0.83
4	Beige / Off-White	59 to 86	-5 to +5	-3 to +23	0.55	0.83
5	Tan	51 to 65	-2 to +7	+6 to +21	0.45	0.83
6	Dark Blue	13 to 35	-7 to +6	-25 to -2	0.25	0.83
7	Med to Light Blue	34 to 55	-12 to -3	-25 to -8	0.32	0.83
8	Dark Brown	17 to 30	-1 to +9	0 to +10	0.25	0.83
9	Med to Light Brown	25 to 58	-2 to 17	+2 to +26	0.32	0.83
10	Dark Green	18 to 45	-20 to -3	-25 to +11	0.25	0.83
11	Med to Light Green	24 to 70	-20 to 0	-25 to +11	0.32	0.83
12	White	76 to 89	-3 to +2	-3 to +10	0.65	0.83
13	Bright White	>85	-3 to +1	-3 to +6	0.70	0.83
14	Black	<26	-1.5 to +1.5	-1.5 to +1.5	0.25	0.83
15	Dark Gray	24 to 42	-4 to +2	-8 to +4	0.25	0.83
16	Med to Light Gray	40 to 77	-4 to +3	-3 to +8	0.35	0.83
17	Pearlescent Colors	25 to 75	-15 to 17	-15 to 24	0.35	0.75

Measured Hunter “L,” “a,” and “b color coordinates are reported in accordance with ASTM E805, Section 9. Colorimetry Equipment Specification: 0°/45° or 45°/0° (illuminant angle /viewing angle) geometry with 10° standard observer, D65 illuminant

APPENDIX 6: PROCEDURES FOR REFORMULATED, RETESTED, OR INACTIVE PRODUCTS

Last updated September 22, 2022

Purpose

Manufacturers occasionally change their product formulation, which can alter the Radiative Properties of the roofing material. When a significant change in the Radiative Properties occur, it is important for the Manufacturer to re-test the product to maintain accuracy in the CRRC Rated Roof Products Directory. Section 3.9 of the CRRC-1 Roof Product Rating Program Manual calls for any product that undergoes a Formula Change (defined as a change in Radiative Properties more than ± 0.05) to obtain a new CRRC product rating, including new initial and aged test results and a new product identification number. If a change is made to a product formulation which results in a change in ratings of less than ± 0.05 , the Licensee may choose to re-rate their product, but is not required to do so. The product rating procedure for a reformulated product consists of the steps outlined in this document. This procedure also describes the handling of inactivated and Terminated products.

Key Definitions

Formula Change: Individual or accumulated changes in resin, pigment, pigment grind, materials ratios, or anything which in aggregate changes Solar Reflectance or Thermal Emittance by ± 0.05 or more.

Inactive Product Rating: Any product rating removed from the CRRC Rated Roof Products Directory due to Licensee request or non-payment of fees and relocated to the Inactive Product Rating List.

Retested Product: A CRRC Rated Roofing Product that replaces an original product rating due to product reformulation, Validation Testing failure, test method changes, or discontinuation for any other reason.

Terminated Product Rating: Any product rating that is permanently removed from the CRRC Rated Roof Products Directory due to Validation Testing failure or retesting requirements and relocated to the Inactive Product Rating List. Terminated products are not eligible for reactivation.

Reactivated Product: A CRRC Rated Roofing Product which was previously inactive and is reactivated by Licensee request.

Reformulated or Retested Product Rating Procedure

1. The Licensee begins a completely new product rating process including initial and aged testing and accompanying fee. For more detailed information, please see the CRRC Product Rating Procedure Details in Appendix 4 of the CRRC-1 Roof Product Rating Program Manual.
2. The following information must be provided to the CRRC:
 - Licensee completes product rating application via the CRRC Online Rating Portal that denotes that either a Formula Change or retesting has occurred on a CRRC Rated Roofing Product and lists the CRRC Product ID for the original formulation.
 - AITL submits the new test results via the CRRC Online Rating Portal.
 - Licensee pays the required fees.
3. The CRRC will review the application. If the application is approved, the CRRC will issue the product a new CRRC product identification (ID) number that will consist of the original formulation ID number followed by a suffix. For example, if the original product had an ID number of 0460-0002, then the reformulated product would be issued an ID number of 0460-0002a. When the application is complete, the CRRC includes initial rating results on the CRRC Rated Roof Products Directory.
4. The rating for the previous formulation(s) will remain on the CRRC Rated Roof Products Directory until the Licensee chooses to have it moved to the Inactive Product Rating List.

-
5. The Licensee shall discontinue labeling all Terminated or inactivated products. The Licensees may use the CRRC Label for the reformulated product, but the label must include the unique CRRC product ID number that includes the assigned letter suffix.
 6. Aged product ratings for Terminated products are not required. However, if the Licensee chooses to undergo aged testing, the CRRC asks that the AITL provide the results to the CRRC, which shall be included on the Inactive Product Rating List. Test farms shall notify the CRRC within 30 calendar days if products have been pulled early from the three-year exposure.

Inactive Product Ratings

1. Inactive Product Ratings, including Terminated products, are moved from the online CRRC Rated Roof Products Directory to the Inactive Product Ratings List. This list is maintained by the CRRC and available upon request; the list will not be posted on the CRRC website.
2. If a product is on the Inactive Product Rating List due to Validation Testing failure or retesting requirements, then that product is considered “Terminated” and may not be reactivated.
3. For non-Terminated products on the Inactive Product Rating List, a product may be reactivated and moved back to the CRRC Rated Roof Products Directory under the following conditions:
 - a. If reactivation happens during the same year as the inactivation, product renewal fees, any applicable late fees, and all other outstanding fees apply.
 - b. If the reactivation happens in a subsequent year from the inactivation, the initial product rating fees apply.
 - c. Previous test data may only be used if the previous testing was conducted in accordance with CRRC testing and weathering procedures in effect at the time of reactivation request. If the previous test data were not obtained in accordance with the testing and weathering procedures in effect at the time of reactivation, the product must reapply (including conducting new testing and weathering) in order to have that product active on the CRRC Rated Roof Products Directory.
4. Aged testing is a mandatory requirement for all active Standard Roofing Products. Test farms shall notify the CRRC within 30 calendar days if products have been pulled early from the three-year exposure. Inactive products that have not completed aged testing are not required to submit aged ratings.

APPENDIX 7: INSTRUCTIONS FOR MEASURING SOLAR REFLECTANCE AND THERMAL EMITTANCE OF ROOFING AGGREGATE LESS THAN OR EQUAL TO 5/8" NOMINAL SIZE

Last updated April 8, 2021

SOLAR REFLECTANCE

Scope

The following document describes the protocol for measuring the Solar Reflectance of aggregate Roofing Products within the CRRC Roof Product Rating Program. The method can be used for medium-sized aggregate, up to 1.59 centimeters (5/8 inch) nominal size. This includes both “loose” aggregate Roofing Products (Aggregate-only products) and aggregate Roofing Products composed of both aggregate and a liquid component (i.e. a coating or adhesive), where the radiative performance of the product depends on both components (Multi-component products). Large aggregate products (e.g., ballast) are not covered by this method. This specification provides guidance to aggregate Manufacturers, CRRC Accredited Independent Test Laboratories (AITL), and CRRC Approved Test Farms on the preparation of Samples, measurement of initial and aged Solar Reflectance, and weathering of Samples. This specification does not include the measurement of Thermal Emittance for this product type.

Background

In the *Solar Energy* article “Reflectometer Measurement of Roofing Aggregate Albedo” (Levinson et al. 2014), Ronnen Levinson and an aggregate Manufacturer partnered to evaluate laboratory methods for measuring the albedo (Solar Reflectance) of roofing aggregate, and compared those measurements against pyranometer measurements made on large beds of roofing aggregate (7.6 m by 7.6 m or 25 ft by 25 ft). Method A from this project, colloquially known as the “Box of Rocks” method, uses a portable reflectometer to measure the reflectance of a solar-opaque pile of loose aggregate held in a small box (usable area of at least 15.24 cm by 15.24 cm or 6 in by 6 in). Method A was found to accurately characterize the albedo of medium sized aggregate (up to 16 mm or 5/8 in), but not that of larger aggregate (e.g., ballast). Method A offers several advantages over ASTM E1918, including ease of Specimen transportation and preparation, and a simple relationship between the albedo R_{ap} of the small pile of aggregate and the albedo R_a of a large bed of the same aggregate. That is, $R_a = R_{ap}$.

Materials required

For each individual Specimen, use a container (box) with an inner footprint of 30 cm by 30 cm (12 in by 12 in). The box must include the following features:

- The box must be made of a material that will not degrade during three-year natural exposure. Recommended materials include 1/16” thick aluminum (3003 grade recommended), stainless steel, or marine-grade plywood. Untreated plywood, pressure-treated plywood, and carbon steel are not recommended as they may warp, corrode, or contaminate the Specimen.
- The box must include stainless steel woven wire mesh on three of the four box walls, extending into the bottom of the box by at least 1.27 cm or 1/2 an inch. If using the CRRC-specified box (see Figure 1 below), the mesh will be inserted between the box frame and the mesh cover. The mesh must be selected by the Licensee and sized appropriately relative to the aggregate size to prevent material loss but allow drainage of water. The overall mesh area on each side must be at least 78 square centimeters or 12 square inches.
- The box wall height must be at least 5 centimeters or 1.9 inches.
- The box must include the appropriate hardware to affix to a plywood test farm exposure rack for the duration of the three-year natural exposure period without interfering with the Specimen.

An example of a specified box is shown in Figure 1 below. CAD drawings specifying the design and assembly of this box can be provided by the CRRC at the Licensee’s request. The Licensee is responsible for the fabrication and assembly of the boxes and must supply assembled boxes to the AITL.

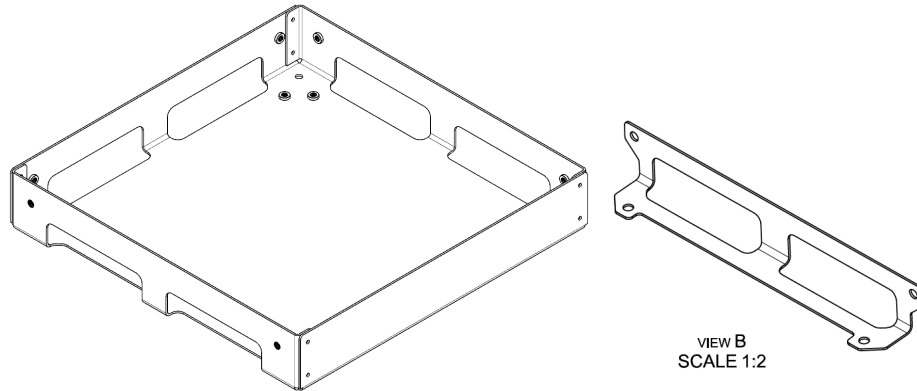

Figure 1. Box and mesh cover design

For each product seeking a CRRC rating, the Licensee must prepare six (6) identical boxes to allow two Specimens (boxes) to be placed at each test farm location (i.e., climate). Nine (9) boxes are recommended to minimize the likelihood that Uncharacteristic Damage renders Specimens unusable. In the case of Uncharacteristic Damage, aggregate products are subject to the requirements described in section 3.5.1 (D) of the CRRC-1 Roof Product Rating Program Manual.

Instructions for Aggregate-only products

The following instructions apply specifically to aggregate-only products.

Instructions for Licensee Prior to Initial Solar Reflectance Testing

1. The Licensee shall determine the appropriate quantity of aggregate to add to the box based on the specified application rate (mass per unit area) of the product. Application instructions or other documentation that details the application rate and any other preparation instructions must be provided to the AITL by the Licensee.
2. For each Specimen (box), the Licensee shall package the required quantity of aggregate in a sealed and labeled bag, for a total of either six (6) or nine (9) bags of aggregate. The Licensee shall label each box with the model name and any other information necessary for product identification.
3. The Licensee shall select from one of the two options below to obtain initial Solar Reflectance measurements. The Licensee shall send the assembled boxes and bags of aggregate to either the Test Farm (Option 1) or AITL (Option 2) as described below.
 - Option 1: The Licensee ships the boxes and bags of aggregate to a CRRC Approved Test Farm with written instructions on how to prepare the test Specimens. These instructions must also be submitted to the CRRC Online Rating Portal at the time of application submission. An AITL technician will travel to the three (3) Test Farm Sites with a portable reflectometer to complete the initial measurements.
 - Option 2: The Licensee ships the boxes and bags of aggregate to an AITL with written instructions on how to prepare the test Specimens. These instructions must also be submitted to the CRRC Online Rating Portal at the time of application submission.

Instructions for AITL - Initial Reflectance Testing

1. The AITL shall weigh each bag of aggregate to ensure that it meets the coverage rate requirements provided in the application instructions. If insufficient product was provided to meet the recommended coverage rate, contact the Licensee to obtain additional product.

2. The AITL shall prepare an opaque, level pile of the aggregate in each Specimen box. The bottom of the box should not be visible and the aggregate should not sit above the walls of the box.
3. The AITL shall take initial Solar Reflectance measurements in accordance with the “Initial and Aged Solar Reflectance Methodology” below.
4. After the initial Solar Reflectance measurements are completed:
 - Option 1: After the AITL technician concludes initial testing in situ at each Test Farm Site, Test Farm staff shall affix the test boxes to the exposure platform as described in the “Instructions for Accredited Test Farm – Weathering,” below, ensuring that the prepared Specimens are not disturbed.
 - Option 2: The AITL returns the aggregate to its respective bags, and re-seals the bags. Specimen boxes, assembly instructions, and the accompanying bags of aggregate are sent to the central Test Farm facility. The Test Farm will then distribute the Specimens to the three (3) test farm locations in accordance with Section 3.5 and Appendix 4 of the CRRC-1 Roof Product Rating Program Manual and the “Instructions for Accredited Test Farm – Weathering,” below.

Instructions for Accredited Test Farm - Weathering

1. If Option 2 (see “Instructions for AITL - Initial Reflectance,” above) was pursued for initial testing, the Test Farm must prepare the Specimens for exposure. Test Farm staff shall prepare an opaque, level pile of aggregate in each Specimen box using the pre-bagged quantity of aggregate. The applied aggregate should not sit above the walls of the box and the bottom of the box should not be visible.
2. Prepared Specimen boxes shall be affixed to the exposure platform using hardware specified in the assembly instructions for the test box. The side of the box that does not contain any mesh should be oriented to face up-slope to ensure proper drainage.
3. In conformance with Section 2.2.10 of the CRRC-1 Roof Product Rating Program Manual, aggregate Specimens shall be exposed on a low-slope array tilted at 5°S.
4. Photos will be taken periodically by Test Farm staff and provided to the CRRC, in conformance with Appendix 4 of the CRRC-1 Roof Product Rating Program Manual.
5. Upon completion of the three-year weathering period, Test Farm staff shall carefully remove the boxes from the exposure racks and bring the Samples indoors without disturbing the aggregate material.
6. Two months before the end of the three-year weathering period, the CRRC will coordinate with the Licensee, AITL, and Test Farm to schedule aged testing. An AITL technician will travel to three (3) Test Farm Sites to conduct aged reflectance testing. The Test Farm shall retain the Specimens for at least 90 calendar days after the AITL conducts aged testing.

Instructions for AITL - Aged Reflectance Testing

1. An AITL technician will travel to the three (3) Test Farm Sites to conduct aged reflectance testing. Per Appendix 4 of the CRRC-1 Roof Product Rating Program Manual, the results of the aged testing must be submitted to the Online Rating Portal by the AITL within three (3) months of the exposure removal date. As such, the AITL should plan to visit the Test Farm Sites to take the aged measurements and report the results prior to this three-month deadline.
2. An AITL technician shall make measurements on each of the three (3) Specimens at each test farm location as described in the “Initial and Aged Solar Reflectance Testing Methodology.” There will be a total of either 50 (if six total Specimens were prepared) or 75 (if nine total Specimens were prepared) spot measurements per location (i.e. climate). The mean of the 50 or 75 measurements is the aged result for that climate, and the aged Solar Reflectance is the mean of the three (3) climates.
3. Photos of the Specimens after the three-year weathering period shall be taken by the AITL technician who conducts the aged testing and shall conform with the requirements in Appendix 4 of the CRRC-1 Roof Product Rating Program Manual.

Instructions for multi-component products

The following instructions apply specifically to multi-component products.

Instructions for Licensee Prior to Initial Solar Reflectance Testing

1. The Licensee shall install the hardware necessary to affix Specimen boxes to a Test Farm exposure rack to the bottom of either six (6) or nine (9) identical boxes. The Licensee shall record the weight of each assembled box (including hardware) in kilograms.
2. The Licensee shall label each box with the product model name and any other information necessary for product identification.
4. The Licensee shall prepare the quantities of liquid component and aggregate component necessary to create the desired number of Specimens (either six or nine) that will be sent to an AITL for initial testing.
5. The Licensee shall ship the assembled boxes and the materials necessary for Specimen preparation to an AITL with written Specimen preparation instructions. These instructions must also be uploaded to the CRRC Online Rating Portal at the time of application submission.

Instructions for AITL - Initial Reflectance Testing

Retain all packing materials to reuse for shipping Specimens to the Test Farm.

1. The AITL shall prepare each Specimen in accordance with the application instructions provided by the Licensee on a flat substrate at least 28 cm by 28 cm (11 in by 11 in) and no more than 2 cm or ½ an inch thick. The AITL shall record the empty box weight, substrate weight and the total prepared Specimen weight in kilograms.
 - o Note: Substrate weight, prepared Specimen weight, and box weight for each Specimen must be provided to the CRRC in addition to application instructions and a Safety Data Sheet.
2. The AITL shall ensure that Specimens have been allowed to cure for at least 48 hours before completing initial Solar Reflectance testing.
3. The AITL shall take initial Solar Reflectance measurements in accordance with the “Initial and Aged Solar Reflectance Methodology” described below.
4. After the measurements are completed, the AITL shall place a 30 cm by 30 cm (12 in by 12 in) square of stiff packing foam⁵ at least 2.54 cm or 1 inch thick over the Specimen, followed by a rigid flat covering such as plywood. These coverings shall be tightly taped to the box to prevent any movement of the Specimen during transit.
5. The AITL shall send the Specimens to the central Test Farm facility. The Test Farm will then distribute the Specimens to the three (3) test farm locations in accordance with Section 3.5 and Appendix 4 of the CRRC-1 Roof Product Rating Program Manual.

Instructions for Accredited Test Farm - Weathering

1. Retain all packing materials to reuse for shipping to the AITL for aged testing.
2. The Test Farm shall place Specimens for the exposure period in accordance with the applicable requirements in the CRRC-1 Roof Product Rating Program Manual and the stipulations below.
3. The side of the box that does not contain any mesh should be oriented to face up-slope to ensure proper drainage.
4. In conformance with Section 2.2.10 of the CRRC-1 Roof Product Rating Program Manual, aggregate Specimens shall be exposed on a low-slope array tilted at 5°S.
5. Photos will be taken periodically by Test Farm staff and provided to the CRRC, in conformance with Appendix 4 of the CRRC-1 Roof Product Rating Program Manual.

⁵ One such example is Grainger product ID 5GCG7: Water-Resistant Closed Cell Tool Organizer Foam Sheets

- Upon completion of the three-year weathering period, Test Farm staff shall carefully remove the boxes from the exposure racks and bring the Samples indoors without disturbing the Specimens. The Test Farm shall carefully repackage and return the Specimens to the AITL in accordance with Appendix 4 of the CRRC-1 Roof Product Rating Program Manual.

Instructions for AITL - Aged Reflectance Testing

- AITLs shall conduct aged testing in accordance with the “Initial and Aged Solar Reflectance Testing Methodology,” with a total of either 50 (if six total Specimens were prepared) or 75 (if nine total Specimens were prepared) spot measurements per location (i.e. climate). The mean of the 50 or 75 measurements is the aged result for that climate, and the aged Solar Reflectance is the mean of the three (3) climates.
- Photos of the Specimens after the three-year weathering period shall be taken by the AITL technician who conducts the aged testing and shall conform with the requirements in Appendix 4 of the CRRC-1 Roof Product Rating Program Manual.

Initial and Aged Solar Reflectance Testing Methodology

- Prepare and calibrate a CRRC-approved portable reflectometer to measure Solar Reflectance in accordance with ASTM C1549. For the Devices & Services Solar Spectrum Reflectometer, use air mass setting 1.5E (SSR v6) or 1.5 (SSR v5) per Section R.S.2.2 of ANSI/CRRC S100. Measurements shall be conducted following the method described below and by Levinson et. al. (2014), section 2.4.
- Keeping the reflectometer measurement port horizontal and lightly touching the surface of the aggregate, measure the Solar Reflectance (one reading per location) of each Specimen at 25 unique locations that do not overlap with each other. An example is shown in Figure 2 below. The CRRC can provide an Excel reporting tool to track the measurements upon request.
- The mean of the 25 measurements is the Solar Reflectance for that Specimen.

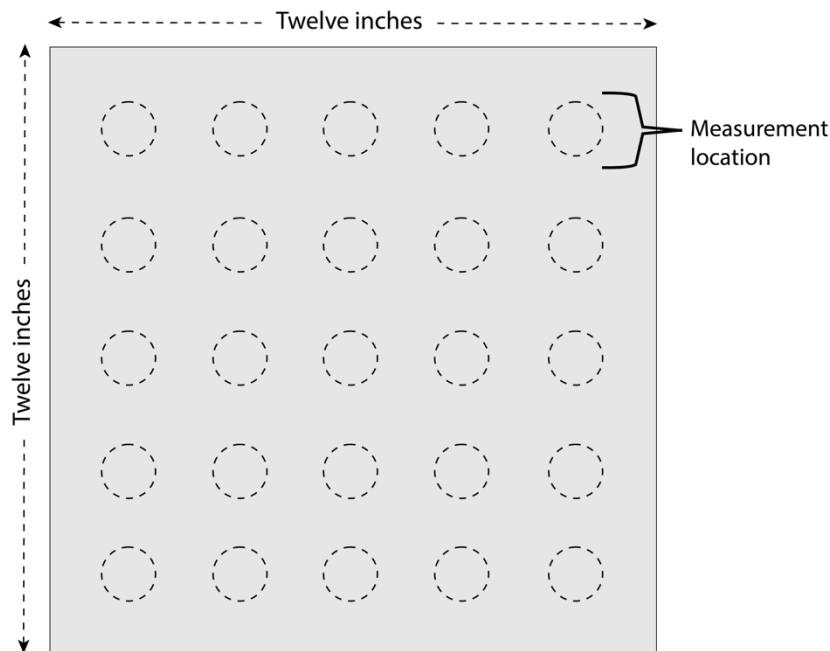

Figure 2. Example measurement template of minimum measurement area

4. Take 25 measurements on each Specimen for a total of either 150 or 225 measurements (for six and nine total Specimens, respectively). The initial Solar Reflectance is the mean of the 150 or 225 measurements.
5. Photos shall be taken of prepared Specimens per the requirements in Appendix 4 of the CRRC-1 Roof Product Rating Program Manual.

Reference

Levinson R, Chen S, Berdahl P, Rosado R, Medina LA. 2014. "Reflectometer measurement of roofing aggregate albedo." *Solar Energy* 100, 159-171. <https://doi.org/10.1016/j.solener.2013.11.006>

Box assembly detail

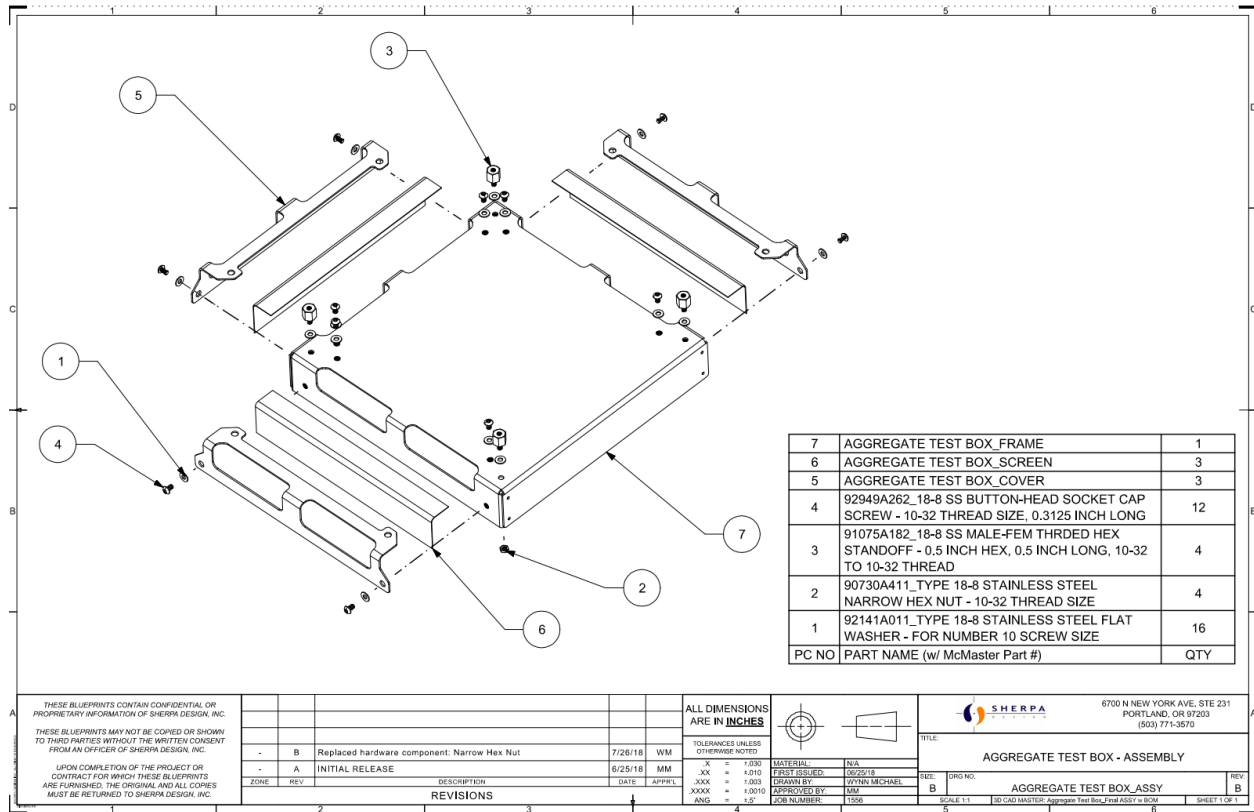

THERMAL EMITTANCE

Moore's Aggregate Thermal Emittance Test Method

Last updated April 8, 2021

Scope

The following describes the protocol for measuring the Thermal Emittance of aggregate Roofing Products within the CRRC Roof Product Rating Program ("Moore's Aggregate Thermal Emittance Test Method"). The method can be used for medium-sized aggregate, up to 1.59 cm (5/8") nominal size. This includes both "loose" aggregate Roofing Products (aggregate-only products) and aggregate Roofing Products composed of both aggregate and a liquid component (i.e., a coating or adhesive), where the radiative performance of the product depends on both components (multi-component products). Large aggregate products (e.g., ballast) are not covered by this method.

Background

Two Thermal Emittance test methods have historically been included in the CRRC Roof Product Rating Program: ASTM C1371 and the Slide Method. ASTM C1371 is intended for flat (planar) Specimens with low thermal resistance, such as metal panels, and is not appropriate for use on roofing aggregate due to the material's higher-than-metal thermal resistance and variable height. The Slide Method adapts the C1371 instrument for use on Specimens with higher thermal resistance, such as concrete or clay Tile, Wood shingles, or insulation-backed membranes. The Slide Method involves moving the device measurement head across the Sample during the measurement process. The Slide Method is not practical on aggregate Roofing Products up to 1.59 cm (5/8") nominal size due to the variable height of the aggregate.

The theory behind the aggregate Thermal Emittance test method described here is outlined in Devices and Services' Technical Note TN79-17 and Appendix 1 of the CRRC-1 Roof Product Rating Program Manual. In short, the measurement head rests in one location for 90 seconds, with readings taken every 15 seconds. To account for the temperature gain associated with leaving the measurement head in this stationary position, the readings are extrapolated back to time zero to obtain the Thermal Emittance result. A correction is then applied to account for the "displacement error" caused by the variable height of the aggregate.

Materials required

- Devices & Services AE1 Emissometer with ADP Port Adapter
- A timer or stopwatch capable of counting up to 90 seconds
- 0.10" plastic spacer (provided by Devices & Services)
- Excel reporting tool

Methodology

Specimen preparation and handling shall adhere to the requirements described in the preceding pages of this appendix.

Specimen displacement measurements

1. Place the ADP adapter on a flat surface (disconnected from the AE1 detector). Using a caliper depth gage, measure the height of the ADP adapter in inches and record the result in the "Displacement measurements" tab of the Excel reporting tool.
2. Place the ADP adapter on top of the Specimen (rocks). Using a caliper depth gage, carefully measure the distance between the Specimen (i.e., rocks) and the top of the ADP port adapter at 30 random locations on the Specimen, disturbing the Specimen as little as possible. Record the readings in inches in the "Displacement measurements" tab of the Excel reporting tool.

Displacement error calibration

1. Affix the ADP adapter to the emissometer detector, then allow 30 minutes for the instrument and adapter to warm up and reach a steady temperature, with the detector resting on the heat sink.
2. Complete calibration of the emissometer in accordance with the device's operating instructions. Rest the detector + adapter on the high emittance standard and allow Thermal Emittance output to stabilize. Once stable for at least one minute, adjust the gain as needed to read the correct value of the high emittance standard.
3. Measure the high emittance standard with a displacement spacer (tabs facing up) between the standard and adapter (see Figure 1). After one minute, record the Thermal Emittance result to three decimal places in the "Displacement calibration" tab of the Excel reporting tool provided by the CRRC.
4. Remove the spacer quickly and immediately place the detector with adapter back on the high emittance standard. After one minute, record the Thermal Emittance result to three decimal places in the Excel reporting tool.
5. Measure the low emittance standard with the displacement spacer (tabs facing up) between the standard and adapter. After one minute, record the Thermal Emittance result to three decimal places in the reporting tool.
6. Remove the spacer quickly and immediately place the detector with adapter back on the low emittance standard. After one minute, measure the low emittance standard and record the Thermal Emittance result to three decimal places in the reporting tool.

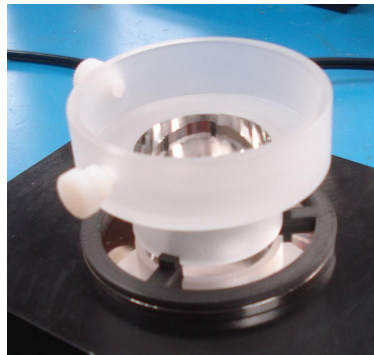

Figure 1. Displacement spacer affixed to ADP adapter

Thermal Emittance measurements

1. Place the prepared Specimen on the right side of the heat sink with a small amount of water under the box.
2. Place the high- and low-emittance standards on the other end of the heat sink with a few drops of water underneath each.
3. Allow fifteen minutes for the Specimen and standards to come to the same temperature.
4. Calibrate the instrument in accordance with the device Manufacturer's instructions.
5. Measure the low emittance standard and record the result in the "Emittance measurement" tab of the Excel reporting tool.
6. Place the detector + adapter on the high-emittance standard and allow three minutes for the output to stabilize. Once stable, adjust the gain as needed to read the correct value of the high emittance standard, and report the reading in the Excel reporting tool.
7. Place the measurement head on the Specimen in a fixed position and record the Thermal Emittance output every 15 seconds for 90 seconds in the Excel reporting tool.
 - a. This will yield 6 measurements per trial (first reading at time = 15 seconds)
8. Return the detector + adapter to the high emittance standard and allow the reading to stabilize. Record the stabilized reading of the high emittance standard in the Excel reporting tool.
9. Repeat steps 6 through 8 three additional times on three unique spots on the Specimen.
 - a. This will yield 24 readings (6 measurements \times 4 locations).
10. The Excel reporting tool will calculate the corrected average Thermal Emittance value for each Specimen.

-
11. Complete steps 1 through 9 on all Specimens (either six or nine total Specimens)
 12. Report the corrected average Thermal Emittance result for each Specimen in the CRRC Online Rating Portal, and upload a copy of the completed Excel reporting tool.

APPENDIX 8: STANDARD TEST METHOD FOR DETERMINING THE DIRECTIONAL-HEMISPHERICAL SOLAR REFLECTANCE OF MATERIALS USING A DIRECTIONAL-HEMISPHERICAL PORTABLE REFLECTOMETER

1. Scope

1.1. This test method covers a technique for determining the directional-hemispherical Solar Reflectance of materials in a laboratory or on-site using a commercial portable reflectometer. The purpose of the test method is to evaluate the reflectance properties of surfaces exposed to solar radiation.

1.2. This test method is applicable to Specimens of materials having both specular and diffuse optical properties.

1.3. This technique is supported by comparing reflectometer measurements with those using ASTM E903-12 test method for Solar Reflectance using integrating spheres.

1.4. This test method refers to applications using standard solar spectral irradiance functions but may be applied using alternative weighting functions if the source and details are reported.

1.5. *This standard does not purport to address the safety concerns, if any, associated with its use. It is the responsibility of the user to establish appropriate safety and health practices and determine the applicability of regulatory limitations.*

2. Referenced Documents

2.1. ASTM Standards:

2.1.1. C1549-16 Standard Test Method for Determination of Solar Reflectance Near Ambient Temperature Using a Portable Solar Reflectometer

2.1.2. C1864-17e1 Standard Test Method for Determination of Solar Reflectance of Directionally Reflective Material Using Portable Solar Reflectometer

2.1.3. E903-20 Standard Test Method for Solar Absorptance, Reflectance, and Transmittance of Materials Using Integrating Spheres

2.1.4. E490-00a (2019) Standard Solar Constant and Zero Air Mass Solar Spectral Irradiance Tables

2.1.5. E891-92 Tables for Terrestrial Direct Normal Solar Spectral Irradiance Tables for Air Mass 1.5

2.1.6. G173-03 (2020) Standard Tables for Reference Solar Spectral Irradiances: Direct Normal and Hemispherical on 37° Tilted Surface

2.1.7. G197-14 (2021) Standard Table for Reference Solar Spectral Distributions: Direct and Diffuse on 20° Tilted and Vertical Surfaces

2.2. Additional References:

2.2.1. Levinson, R.; Akbari, H.; Berdahl, P.; “Measuring Solar Reflectance-Part I: Defining a metric that accurately predicts solar heat gain”, *Solar Energy* **84**, 1717-1744 (2010).

2.2.2. Gueymard, C.; “Simple Model of the Atmospheric Radiative Transfer of Sunshine (SMARTS) 2.9.5.” <<http://www.nrel.gov/grid/solar-resource/smarts.html>>.

3. Terminology

3.1. Definitions – The definitions in ASTM C1549-16, ASTM E903-12, and Levinson *et al.* (2010) are applicable to this method.

3.2. Definitions of terms specific to this standard:

3.2.1. Directional-hemispherical reflectance – ratio of the total energy reflected into the subtending hemisphere to the energy incident on the surface from a given direction.

3.2.2. Directional-hemispherical in-band reflectance – directional-hemispherical reflectance for a given wavelength band (i.e. measured by a given detector).

3.2.3. Solar spectral irradiance – power of electromagnetic radiation received from the Sun per unit area as a function of wavelength.

3.3. Symbols:

3.3.1. λ – Wavelength of light, nm.

3.3.2. R_{solar} – Directional-hemispherical Solar Reflectance, dimensionless.

3.3.3. $R_{in-band,j}$ – Directional-hemispherical in-band reflectance measured by detector j , dimensionless.

3.3.4. $\rho(\lambda)$ – Directional-hemispherical spectral reflectance, dimensionless.

3.3.5. $i(\lambda)$ – Solar spectral irradiance, $W/m^2 \cdot nm$.

4. Summary of Test Method

4.1. This test method uses a commercial portable reflectometer to characterize the directional-hemispherical Solar Reflectance of a material. The test Specimen is illuminated at 20° from normal and the directional-hemispherical reflectance is measured in seven wavelength bands from approximately 335 to 2,500 nm utilizing an integrating sphere equipped with an array of detectors and filters.

4.2. The instrument’s software calculates the directional-hemispherical Solar Reflectance or absorptance by taking a weighted average of the directional-hemispherical in-band reflectances using a standard or custom solar spectral irradiance as the weighting function.

5. Significance and Use

5.1. Exposure to solar radiation is primary concern for construction materials, aerospace vehicles, solar power devices, and any application where a surface is exposed to solar radiation. The property called “Solar Reflectance” is defined as the fraction of incident solar radiation reflected by a surface.

5.2. This test method is designed to provide reproducible data on-site or in the lab. Use this method to compare results among laboratory or on-site facilities, compare results from different times by the same facility, or compare data obtained on different materials. This method can be used to monitor changes in directional-hemispherical Solar Reflectance due to aging, exposure, or other dynamic processes.

5.3. Directional-hemispherical Solar Reflectance affects the heat balance of the building envelope and the performance of solar energy systems, including photovoltaic devices and solar thermal energy collectors.

5.4. Directional-hemispherical Solar Reflectance is critical for the thermal control of spacecraft and the solar power of extraterrestrial systems.

5.5. This test method provides a means for determining directional-hemispherical Solar Reflectance for both terrestrial and extraterrestrial conditions using either standard solar spectral irradiance or alternative weighting functions.

5.6. This test method is appropriate for smooth and rough materials having both specular and diffuse optical properties. Some structured anisotropic materials may require special consideration because of the azimuthal angular dependence of the reflectance. For such cases, an average directional-hemispherical Solar Reflectance can be determined by making measurements at several orientations (refer to ASTM C1864-17).

6. Apparatus

6.1. This test method applies to directional-hemispherical Solar Reflectance determination with a commercial portable reflectometer. The instrument utilizes the principles of an integrating sphere for performing optical reflectance measurements in the spectral region of 335 to 2,500 nm. The instrument consists of two units, the Measurement Head and the Command Module (Fig. 1).

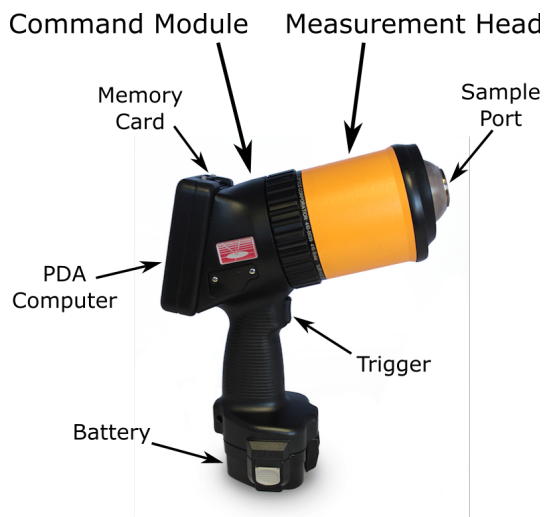

Figure 1. 410-Solar-i Reflectometer by Surface Optics Corporation

6.1.1. Measurement Head – The Measurement Head is constructed around an integrating sphere for measurements of directional-hemispherical reflectance. Light from a tungsten halogen lamp enters the integrating sphere through an internal beam port

and illuminates the test Specimen at the Sample port at a 20° angle of incidence. The test Specimen scatters light back into the integrating sphere where it is uniformly diffused. A portion of the light reaches the detector arrays which are used to measure the directional-hemispherical in-band reflectance. Optical filters and detector arrays cover seven spectral bands in the wavelength range of 335 to 2,500 nm (335-380, 400-540, 480-600, 590-720, 700-1,100, 1,000-1,700, and 1,700-2,500 nm). A rubber ring protects the measured surface from contact with the metal surface of the integrating sphere and provides a non-skid surface to press against the Sample surface.

6.1.2. Command Module – The Command Module provides computer processing, electrical power, and structural support for the Measurement Head. The Command Module housing contains the Trigger, Battery Cartridge, a small Personal Digital Assistant (PDA) type computer, Light Emitting Diode (LED) & Vibrator Motor indicators, Secure Digital (SD) card port, Measurement Head mechanical and electrical connections, Input/Output port, and safety strap. The computer is located at the top of the handle with a touch screen display that faces the user during operation. The user controls the unit by selecting various software functions from the touch screen interface and pressing the trigger when a measurement is to be made.

6.2. Calibration Coupons – Calibration of the reflectometer is accomplished with a Manufacturer-supplied calibration coupon. The reflectance values of the provided coupon are stored on the supplied SD card. Zero reflectance is measured with no Sample present at the Sample port of the integrating sphere. The Measurement Head must be pointed away from artificial light sources, such as fluorescent lighting,

during the Zero measurement.⁶ During the calibration process (and during each Sample measurement cycle), the instrument automatically makes an additional measurement of the light beam reflected off a specific location on the wall of the integrating sphere. A ratio of the electrical signal generated by the detector when the beam illuminates the Sample to that when the beam illuminates the reference point on the integrating sphere is used in the calculation of Sample reflectance values. This normalization process eliminates most of instrument drift that might be caused by thermal or electrical system instabilities.

6.3. Test Specimens – Specimens to be tested can be flat, concave (inner diameter larger than 15 cm), or convex (outer diameter larger than 8 cm), and may have specular or diffuse characteristics. The Sample is illuminated with an elliptical spot of about 12 mm at the major axis and 6 mm at the minor axis. The Sample port of the integrating sphere is pressed flush against the measured surface, which must have a minimum dimension of 13 mm.

7. Procedure

7.1. Setup – The instrument is powered from a 12 volt battery. The battery must be charged in the Manufacturer-supplied battery charger prior to first use. The battery is inserted in the bottom of the Command Module by the user. The instrument is powered up by pressing the trigger located at internal top of the handle. The instrument boots to the Main Operation menu displayed on the computer screen. The user can adjust various parameters through the

Setup menu. The instrument shall be calibrated after at least 5 min. of warm-up time.

7.1.1. Calibration Setup – The **Calibration Setup** menu contains the known reflectance values of the calibration coupon. These values are provided by the Manufacturer and must match the supplied calibration coupon.

7.1.2. Device Setup – The **Device Setup** menu contains various device parameters which alter the performance conditions of the instrument. The factory settings are appropriate for most measurements. Most commonly, the user might adjust Points (number of readings averaged during one measurement), Cal X (number of repetitions during calibration procedure), and Sample X (number of measurements used to generate statistics).

7.2. Calibration – From the main menu, press **Calibration** to display the Calibration screen. The computer screen guides the user through the calibration process using the calibration coupon. The coupon requires a set of calibration values, which are entered under the Calibration Setup menu and are stored in a file on the SD card. The name of the current calibration file is displayed at the top of the calibration screen. To select a different calibration file, press the button with the calibration name, make selection. Remove the Sample port cap from the integrating sphere and hold the calibration coupon flat against the Sample port and press the trigger. Continue to hold the coupon over the Sample port during the measurement. The LED and vibrator motor will indicate that the measurement step is complete. Remove the calibration coupon from in front of the Sample port and press the

⁶ A chopper modulates the light source at ~100 Hz. The electrical signals generated by the detector are filtered via lock-in amplification such that the only

signals extracted are those modulating at the reference frequency (100 Hz). Artificial light sources, such as fluorescent lighting, can flicker close to this frequency and contribute to the measurement.

trigger with nothing blocking the Sample port (do not aim at fluorescent lights). The LED and vibrator motor will indicate that the calibration is complete. Press the back arrow at the bottom of the screen to return to the Main Menu. Repeat the calibration procedure every time the instrument is turned on and after extreme changes in the environment (e.g. temperature, humidity).

7.3. Measurement – Press the **Measurement** button on the Main Menu screen. All data taken with the 410-Solar-i are saved into a data file (*.ems) and stored on the SD card. The file name is displayed on the grey button under the screen title. The Sample name is indicated on the second button. To change the file name and/or the Sample name press the appropriate button. The software keeps a list of the data files on the card. Take the unit to the surface to be tested. Press the Sample port tight against the measured object and press the trigger. Continue to hold the Sample port against the measured surface while the measurement is taken and the hourglass indicator is shown. To indicate that the measurement is finished, the hourglass will disappear, the LED in the upper left-hand corner of the PDA housing will light, and the handle will vibrate. The measurement results are saved and displayed in a column on the PDA screen. The graphical representation of the data can be viewed by pressing the Graph button. Each reflectance value is plotted at the measured value across the entire spectral band. The instrument can be pre-set to display either directional-hemispherical Solar Reflectance or absorptance, this setting is done in the Device Setup. To view the directional-hemispherical Solar Reflectance value, press the ρ (rho) button at the bottom of the screen. Under that screen the solar spectral irradiance can be selected.

7.4. Calculation – Before a test is performed, press the small button marked “[n]x” to enter the number of readings to be performed and averaged. Upon completion of the first reading, the color of the [n]x button changes from black to red, the number of measurements is lowered by 1, and the reflectance values and directional-hemispherical Solar Reflectance are displayed. Continue taking measurements until the color of the button changes back to black. The screen will then display a column of averaged reflectance values and the standard deviation for each of those values. The averaged directional-hemispherical Solar Reflectance and its standard deviation are also displayed. All values are automatically stored on the SD card.

7.5. Directional-Hemispherical Solar Reflectance – The instrument measures the directional-hemispherical reflectance of a test Specimen in each of the seven spectral bands listed in Section 6.1.1. Directional-hemispherical spectral reflectance $\rho(\lambda)$ is estimated as a simple step function from the seven directional-hemispherical in-band reflectances. Directional-hemispherical Solar Reflectance R_{solar} is computed as the weighted average of the directional-hemispherical spectral reflectance, where the solar spectral irradiance $i(\lambda)$ is the weighting function. That is,

$$R_{solar} = \frac{\int_{\lambda_1}^{\lambda_2} \rho(\lambda) \times i(\lambda) d\lambda}{\int_{\lambda_1}^{\lambda_2} i(\lambda) d\lambda} \quad (1)$$

where the limits λ_1 and λ_2 are 250 and 2,500 nm. Note, the reflectance from 335 nm is linearly extrapolated out to 250 nm for this calculation.

7.5.1. Solar Spectral Irradiance – The user can select one of the standard solar spectral irradiances provided with the instrument or their own custom weighting

function via the **Solar Irradiance** drop-down menu located in the **Directional-Hemispherical Solar Reflectance** screen. Standard solar spectral irradiances are denoted using the same initialism as Levinson *et al.* (2010). For terrestrial applications use E891BN (ASTM E891-92), AM1GH (Gueymard, 2006), G173GT (ASTM G173-12), G197GT20 (ASTM G197-14), G197GT90 (ASTM G197-14), or AM1.5GH (Gueymard, 2006). For extraterrestrial applications use AM0 (ASTM E490-14). Custom weighting functions are added as a *.jfn file to the **Program** directory on the SD card.

7.6. Evaluation of a Surface – Quantify the variability of the directional-hemispherical Solar Reflectance with position on a test Specimen by measuring three or more locations on the surface.

8. Report

8.1. Reporting requirements shall be in accordance with ASTM C1549.

9. Precision and Bias

9.1. Precision – Precision statistics were determined for SOC 410-Solar-i portable reflectometer measurements of the 26 materials shown in Table 1. The Samples include roofing materials and paints. Here, “panel” refers to a smooth rectangular metal sheet as the base material and “shingle” refers to a rough rectangular felt mat as the base material. Based on the standard deviation of those measurements, the precision was found to be within 0.02 reflectance units (scale of 0 to 1).

9.2. Bias – Directional-hemispherical Solar Reflectance values calculated using the air mass 1.5 global tilt solar spectral irradiance specified by ASTM G173-12 were obtained for 26 materials using ASTM E903-12. These measurements were used to assess the

bias of the SOC 410-Solar-i from ASTM E903-12 which is shown in Table 1. The 410-Solar-i test method yields directional-hemispherical Solar Reflectance results that are 0.004 higher than those obtained with ASTM E903-12.

Table 1. Comparison of directional-hemispherical Solar Reflectance measurements on 26 Samples using the SOC 410-Solar-i portable reflectometer and a spectrophotometer operated according to E903-12. Directional-hemispherical Solar Reflectance values are calculated using the air mass 1.5 global tilt solar spectral irradiance specified by ASTM G173-12.

Coating	Cary 5000	410-Solar-i
White Knight Plus on Panel	0.82	0.82
White Knight Plus on Shingle	0.80	0.80
Pyramic on Panel	0.82	0.80
Pyramic on Shingle	0.82	0.81
White Coating	0.84	0.84
TPO	0.77	0.76
Beige Acrylic	0.69	0.70
Aluminized Shingle	0.64	0.64
EPDM	0.16	0.15
Shingle	0.17	0.17
Silver Shadow	0.27	0.28
Red Metallic	0.45	0.46
Duke Blue	0.30	0.31
Saffron Metallic	0.49	0.50
Ultra Cool Pewter	0.41	0.43
Russet Metallic	0.29	0.30
Nike Orange	0.51	0.53
Sandstone	0.58	0.58
Copper	0.43	0.44
Aged Copper	0.29	0.30
Zinc Yellow	0.66	0.68
Matte Black	0.09	0.09
Decisive Yellow	0.71	0.73
Seekonk Purple	0.24	0.23
Regal White	0.73	0.73
Weathered Zinc	0.29	0.30

10. Keywords

10.1. portable; handheld; reflectometer; solar; spectral; reflectance; directional; hemispherical; ultraviolet; visible; near infrared;

11. Suitable Practices

11.1. Do not overreach. Always keep proper footing and balance.

11.2. Be sure that no one is below when using the unit in high locations.

11.3. Use of the lanyard is encouraged but do not carry the unit using only the lanyard.

11.4. Do not drop, shake, or strike the unit.

11.5. Do not remove the two screws in the factory diagnostics port cover. Removal of the screws or cover or accessing the port will void the warranty.

11.6. Be careful not to scratch or physically damage the screen.

11.7. Protect against electrostatic discharge.

11.8. Do not store at temperatures below -25 °C (-13 °F) or above 70 °C (158 °F).

11.9. Warm unit to at least 0 °C (32 °F) for two hours before using if stored below 0 °C (32 °F).

11.10. Do not operate at ambient temperatures below 0 °C (32 °F) or above 50 °C (122 °F).

11.11. The integrating sphere is a critical component of the instrument. Care should be taken to avoid contaminating the integrating sphere. When possible, make measurements pointing the reflectometer downwards.

11.12. Replace the sampling port cap when not taking measurements to minimize contamination of the integrating sphere.

11.13. Use the storage container or another airtight barrier when not in use.

11.14. Avoid working in heavy fog, snow, or rain, or under conditions of blowing dust.

11.15. Avoid placing the 410 on any surface covered with movable dust or dirt, such as the ground or floor.

11.16. Do not put any objects or solvents inside the integrating sphere. Do not blow air into the integrating sphere including electronics cleaning products.

11.17. The surface of the calibration coupon should be protected from scratches and contamination. Do not touch the surface of the calibration coupon.

11.18. Always cover the calibration coupons and put away immediately after calibration is complete. Replace the calibration coupon if it becomes damaged or contaminated.

APPENDIX 9: PROCEDURES FOR PRODUCT RETESTING

Last updated September 19, 2019

CRRC Technical Guidelines for Determining Retesting Requirements of a Proposed Test Method

The purpose of these guidelines is to serve as a guide for the CRRC when considering the adoption of a new test method or substantive changes to an existing test method. “Test Method” includes, but is not limited to, ASTM test methods and CRRC-developed test methods. These guidelines do not apply to administrative edits to existing test methods. The applicability of these guidelines is determined by the CRRC Technical Committee.

1. Is the new method at least as accurate as current method?
 - a. Relative to a standard (an accepted reference Specimen, such as a NIST traceable calibration standard)
 - b. Based on known scientific principle (in absence of a standard).
2. Conduct Interlaboratory study comparing two methods
 - a. Within lab (repeatability)
 - i. Is precision of new method at least as good as old method?
 - b. Between lab (reproducibility)
 - i. Can different labs obtain similar results?
3. Technical analysis: Should a switch be made to new method?
 - a. More accurate and more precise – Yes
 - b. More accurate but less precise – Case-by-case to be evaluated by Technical Committee and Board
 - c. Less accurate but more precise - Case-by-case to be evaluated by Technical Committee and Board
 - d. Less accurate and less precise – No
4. Decide whether to switch to new method (Board approval required).
5. Apply practical significance test to determine which products on the CRRC Rated Roof Products Directory must be retested
 - a. Use E1980 to determine the change in Solar Reflectance or Thermal Emittance between the old method and the new method. Products are considered to “pass” the practical significance test if:
 - i. change in SR is less than or equal to ± 0.05
 - ii. change in TE is less than or equal to ± 0.10
6. If needed, apply statistical methodology to determine which products on the CRRC Rated Roof Products Directory must be retested
 - a. Detectable difference
 - b. Reasonable Sample size
 - c. Alpha
 - d. Beta

CRRC Product Retesting Policy Guidelines for Determining Retesting Requirements of a Proposed Test Method

The purpose of this policy guide is to serve as a guide for the CRRC when determining the retesting implications following the adoption of a new test method or substantive changes to an existing test method. “Test method” includes, but is not limited to, ASTM test methods and CRRC-developed test methods. This policy does not apply to administrative edits to existing test methods. This guide is triggered by approval of the adoption of a new test method or changes to an existing test method deemed substantive by the CRRC Board of Directors (Board). All other cases will be evaluated by the Technical Committee.

1. The CRRC Technical Guidelines for Determining Retesting Requirements of a Proposed Test Method (Technical Guidelines) must be applied for any test method change. Apply the practical significance methodology followed by the statistical methodology, if needed, to determine which products on the CRRC Rated Roof Products Directory may require retesting. Additional details are contained in the Technical Guidelines.
2. Once the set of affected products has been determined, the retesting policy considerations described below are followed.
 - a. Retesting requirements: Licensees may choose from the options below to comply with retesting requirements:
 - i. The rated products required to be retested will remain on the CRRC Rated Roof Products Directory until both initial and aged test data for the retested products are approved in the CRRC Online Rating Portal. Upon approval of the aged retesting data, the existing listing on the CRRC Rated Roof Products Directory shall be Terminated and moved to the Inactive Products List, and the Retested Product data will be listed on the CRRC Rated Roof Products Directory. Until the existing listing is Terminated, the Licensee shall be responsible for renewals fees associated with both the existing and Retested Product listings.
 - ii. The rated products required to be retested will remain on the CRRC Rated Roof Products Directory until initial test data for the retested products are approved in the CRRC Online Rating Portal. Upon approval of the initial retesting data, the existing listing on the CRRC Rated Roof Products Directory shall be Terminated and moved to the Inactive Products List, and the retested initial product data will be listed on the CRRC Rated Roof Products Directory. Aged ratings will be displayed as “Pending.” Licensees may elect to seek Rapid Ratings testing until three-year aged ratings become available, per section 3.5.6 of the CRRC-1 Roof Product Rating Program Manual.
 - b. Retesting Timeline: Initial test data for retested products must be submitted to the CRRC Online Rating Portal within four (4) months of the retesting effective date. Additional time may be granted based on the number of products affected, product availability, and the complexity of retesting for the affected product type(s). If data are not submitted to the CRRC Online Rating Portal within four (4) months or the timeline approved by the Board, the existing product ratings will be Terminated from the CRRC Rated Roof Products Directory.
 - c. Licensees with more than 10 products requiring retesting or products affected by product availability may be granted an extension on the retesting timeline to mitigate financial burden.
 - d. The existing rating will be Terminated after either the initial or aged retest data is approved by the CRRC, depending on the Licensee’s choice in step 2a.

-
- i. Licensees must immediately take action to discontinue use of the existing product labels and transition to new labels containing the Retested Product information. This includes but is not limited to ordering new labels, updating artwork, and/or updating marketing materials. Additional detail is provided in section 3.9 of the CRRC-1 Roof Product Rating Program Manual. A transition of one year will be allowed for existing labels.
 - e. Retesting Fees: Unless an exception is deemed appropriate by the Board, retesting ratings will be subject to the CRRC Fees & Dues Structure.
 - 3. Upon Board approval of the retesting policy considerations, a notification period of at least 30 calendar days will be observed. During this period, the CRRC will notify Licensees of retesting requirements and educate Licensees on the retesting protocol. The retesting timeline described in item 2b. shall take effect after this notification period.
 - a. During the notification period, Licensees with products that require retesting will be notified with a formal letter. This letter shall include a description (Brand and model number, CRRC ID) of the specific CRRC-rated products affected. The letter shall also include the action required of the Licensee and the timeline to complete the required action(s).